

FTLX8574D3BNL

Extended Temperature 10Gb/s 850nm SFP+ Datacom Transceiver

FTLX8574D3BNL Extended Temperature 10Gb/s SFP+ transceivers are designed for use in 10-Gigabit Ethernet links over multimode fiber. They are compliant with SFF-8431¹, SFF-8432², IEEE 802.3-2012 10GBASE-SR/SW3 and 10G Fibre Channel 1200-Mx-SN-I4. Digital diagnostics functions are available via a 2-wire serial interface, as specified in SFF-8472⁵. The FTLX8574D3BNL is a “limiting module”, i.e., it employs a limiting receiver. Host board designers using an EDC PHY IC should follow the IC manufacturer’s recommended settings for interoperating the host-board EDC PHY with a limiting receiver SFP+ module. The optical transceiver is compliant per the RoHS Directive 2011/65/EU⁶. See Finisar Application Note AN-2038⁷ for more details.



FEATURES

- Hot-pluggable SFP+ footprint
- Supports 9.95 to 10.5 Gb/s bit rates*
- Power dissipation < 1W
- RoHS-6 compliant (lead-free)
- Commercial temperature range -5°C to 85°C
- Single 3.3V power supply
- Maximum link length of 400m on OM4 MMF
- Uncooled 850nm VCSEL laser
- Receiver limiting electrical interface
- Duplex LC connector
- Built-in digital diagnostic functions

APPLICATIONS

- 10GBASE-SR/SW 10G Ethernet
- 1200-Mx-SN-I 10G Fibre Channel

Product Selection

FTLX8574D3BNL

*Contact Finisar for higher data-rate support up to 11.1Gbps.

I. Pin Descriptions

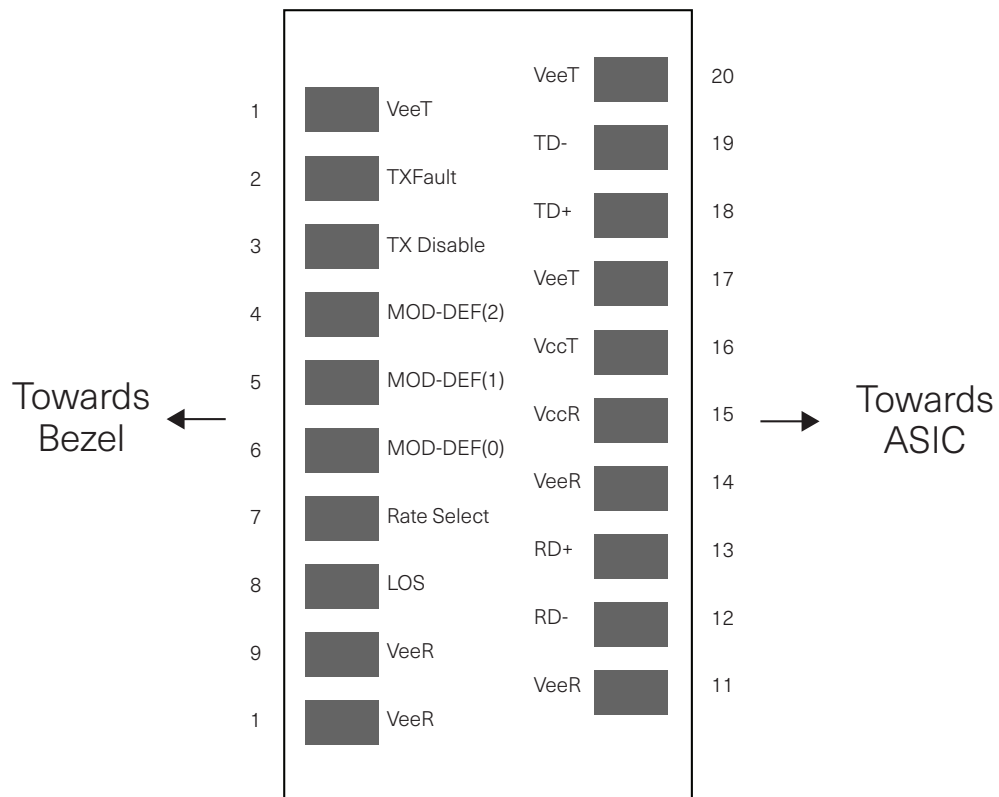

Diagram of Host Board Connector Block Pin Numbers and Names

Pin	Symbol	Name/Description	Notes
1	V _{EET}	Transmitter Ground (Common with Receiver Ground)	1
2	T _{FAULT}	Transmitter Fault.	2
3	T _{DIS}	Transmitter Disable. Laser output disabled on high or open.	3
4	SDA	2-wire Serial Interface Data Line (MOD-DEF2)	4
5	SCA	2-wire Serial Interface Clock (MOD-DEF1)	4
6	MOD_ABS	Module Absent, connected to V _{EET} or V _{EER}	4
7	RS0	No connection required	
8	RX_LOS	Loss of Signal indication. Logic 0 indicates normal operation.	5
9	RS1	No connection required	
10	V _{EER}	Receiver Ground (Common with Transmitter Ground)	1
11	V _{EER}	Receiver Ground (Common with Transmitter Ground)	1
12	RD-	Receiver Inverted DATA out. AC Coupled	
13	RD+	Receiver Non-inverted DATA out. AC Coupled	
14	V _{EER}	Receiver Ground (Common with Transmitter Ground)	1
15	V _{CCR}	Receiver Power Supply	
16	V _{CCT}	Transmitter Power Supply	
17	V _{EET}	Transmitter Ground (Common with Receiver Ground)	1
18	TD+	Transmitter Non-Inverted DATA in. AC Coupled.	
19	TD-	Transmitter Inverted DATA in. AC Coupled.	
20	V _{EET}	Transmitter Ground (Common with Receiver Ground)	1

- Notes
1. Circuit ground is internally isolated from chassis ground.
 2. T_{FAULT} is an open collector/drain output, which should be pulled up with a 4.7k – 10k Ohms resistor on the host board if intended for use. Pull up voltage should be between 2.0V to V_{cc} + 0.3V. A high output indicates a transmitter fault caused by either the TX bias current or the TX output power exceeding the preset alarm thresholds. A low output indicates normal operation. In the low state, the output is pulled to <0.8V.
 3. Laser output disabled on T_{DIS} >2.0V or open, enabled on T_{DIS} <0.8V.
 4. Should be pulled up with 4.7kΩ – 10kΩ on host board to a voltage between 2.0V and 3.6V. MOD_ABS pulls line low to indicate module is plugged in.
 5. LOS is open collector output. Should be pulled up with 4.7k– 10kΩ on host board to a voltage between 2.0V and 3.6V. Logic 0 indicates normal operation; logic 1 indicates loss of signal.

II. Absolute Maximum Ratings

Exceeding the limits below may damage the transceiver module permanently.

Parameter	Symbol	Min	Typ	Max	Unit	Ref.
Maximum Supply Voltage	V _{CC}	-0.5		4.0	V	
Storage Temperature	T _s	-40		85	°C	
Case Operating Temperature	T _{OP}	-5		85	°C	
Relative Humidity	RH	0		85	%	1

Notes:

1. Non Condensing

III. Electrical Characteristics (T_{OP} = -5 to 85°C, V_{CC} = 3.14 to 3.46 Volts)

Parameter	Symbol	Min	Typ	Max	Unit	Ref.
Supply Voltage	V _{CC}	3.15		3.46	V	
Supply Current	I _{CC}			250	mA	
Transmitter						
Input differential impedance	R _{in}		100		Ω	1
Differential data input swing	V _{in,pp}	180		700	mV	
Transmit Disable Voltage	V _D	2		V _{CC}	V	
Transmit Enable Voltage	V _{EN}	V _{EE}		V _{EE} + 0.8	V	
Receiver						
Differential data output swing	V _{out,pp}	300		850	mV	2,6
Data output rise time, fall time	t _r	28			ps	3
LOS Fault	V _{LOS fault}	2		V _{CC HOST}	V	4
LOS Normal	V _{LOS norm}	V _{EE}		V _{EE} +0.8	V	4
Power Supply Noise Tolerance	V _{CC} T/V _{CC} R	Per SFF-8431 Rev 4.1			mVpp	5

Notes:

1. Connected directly to TX data input pins. AC coupling from pins into laser driver IC.
2. Into 100Ω differential termination.
3. 20 – 80 % . Measured with Module Compliance Test Board and OMA test pattern. Use of four 1's and four 0's in sequence in the PRBS⁹ is an acceptable alternative. SFF-8431 Rev 4.1
4. LOS is an open collector output. Should be pulled up with 4.7kΩ – 10kΩ on the host board. Normal operation is logic 0; loss of signal is logic 1. Maximum pull-up voltage is 5.5V.
5. Testing methodology per SFF-8431. Rev 4.1
6. The FTLX8574D3BNL is a "limiting module", i.e., it employs a limiting receiver. Host board designers using an EDC PHY IC should follow the IC manufacturer's recommended settings for interoperating the host-board EDC PHY with a limiting receiver SFP+ module.

IV. Optical Characteristics ($T_{OP} = -5$ to 85°C , $V_{CC} = 3.14$ to 3.46 Volts)

Parameter	Symbol	Min	Typ	Max	Unit	Ref.	
Transmitter							
Optical Modulation Amplitude (OMA)	P_{OMA}		-1.5		dBm	1	
Average Launch Power	P_{AVE}	-5		-1	dBm	2	
Optical Wavelength	λ	840	850	860	nm	1	
RMS Spectral Width	$\Delta\lambda_{rms}$			0.45	nm	1	
Optical Extinction Ratio	ER	3.0	5.5		dB		
Transmitter and Dispersion Penalty	TDP			3.9	dB		
Average Launch power of OFF transmitter	P_{OFF}			-30	dBm		
Tx Jitter	Txj	Per IEEE 802.3-2012 requirements					
Encircled Flux	$<4.5 \mu\text{m}$			30	%	3	
	$<19\mu\text{m}$	86					
Relative Intensity Noise	$RIN_{12,OMA}$			-128	dB/Hz		
Receiver							
Receiver Sensitivity (OMA) @ 10.3Gb/s	R_{SENS1}			-11.1	dBm	4	
Stressed Receiver Sensitivity (OMA) @ 10.3Gb/s	R_{SENS2}			-7.5	dBm	5	
Maximum Input Power	P_{MAX}	+0.5			dBm		
Wavelength Range	λ_C	840		860	nm		
Receiver Reflectance	R_{rx}			-12	dB		
LOS De-Assert	LOS_D			-14	dBm		
LOS Assert	LOS_A	-30	-23		dBm		
LOS Hysteresis		0.5			dB		

Notes:

1. Per Tradeoff Table 52.8, IEEE 802.3-2012.
2. Average Power figures are informative only, per IEEE802.3-2012.
3. Measured into Type A1a (50/125 μm multimode) fiber per ANSI/TIA/EIA-455-203-2.
4. Measured with worst ER; BER $<10^{-12}$; $2^{31} - 1$ PRBS.
5. Per IEEE 802.3-2012.

V. General Specifications

Parameter	Symbol	Min	Typ	Max	Unit	Ref.
Bit Rate	BR	9.95		10.5	Gb/s	1
Bit Error Ratio	BER			10 ⁻¹²		2
Maximum Supported Distances						
Fiber Type	850nm OFL Bandwidth					
62.5 μm	160 MHz-km	Lmax		26	m	
	OM1 200 MHz-km			33		
50 μm	400 MHz-km			66		
	OM2 500 MHz-km			82		
	OM3 2000 MHz-km			300		
	OM4 4700 MHz-km			400		

Notes:

1. 10GBASE-SR/SW. Contact Finisar for higher data-rate support.

2. Tested with a 2³¹ – 1 PRBS

VI. Environmental Specifications

Finisar 850nm SFP transceivers have a commercial operating temperature range from 5°C to +85°C case temperature.

Environmental Specifications	Symbol	Min	Typ	Max	Units	Ref.
Case Operating Temperature	T _{op}	-5		85	°C	
Storage Temperature	T _{sto}	-40		85	°C	

VII. Regulatory Compliance

Finisar transceivers are Class 1 Laser Products and comply with US FDA regulations. These products are certified by TÜV and CSA to meet the Class 1 eye safety requirements of EN (IEC) 60825 and the electrical safety requirements of EN (IEC) 60950. Copies of certificates are available at Finisar Corporation upon request.

VIII. Digital Diagnostic Functions

Finisar FTLX8574D3BNL SFP+ transceivers support the 2-wire serial communication protocol as defined in the SFP MSA^f. It is very closely related to the E²PROM defined in the GBIC standard, with the same electrical specifications.

The standard SFP serial ID provides access to identification information that describes the transceiver's capabilities, standard interfaces, manufacturer, and other information.

Additionally, Finisar SFP transceivers provide an enhanced digital diagnostic monitoring interface, which allows real-time access to device operating parameters such as transceiver temperature, laser bias current, transmitted optical power, received optical power and transceiver supply voltage. It also defines a sophisticated system of alarm and warning flags, which alerts end-users when particular operating parameters are outside of a factory set normal range.

The SFP MSA defines a 256-byte memory map in E²PROM that is accessible over a 2-wire serial interface at the 8 bit address 1010000X (A0h). The digital diagnostic monitoring interface makes use of the 8 bit address 1010001X (A2h), so the originally defined serial ID memory map remains unchanged. The interface is identical to, and is thus fully backward compatible with both the GBIC Specification and the SFP Multi Source Agreement. The complete interface is described in Finisar Application Note AN-2030: "Digital Diagnostics Monitoring Interface for SFP Optical Transceivers".

The operating and diagnostics information is monitored and reported by a Digital Diagnostics Transceiver Controller (DDTC) inside the transceiver, which is accessed through a 2-wire serial interface. When the serial protocol is activated, the serial clock signal (SCL, Mod Def 1) is generated by the host. The positive edge clocks data into the SFP transceiver into those segments of the E²PROM that are not write-protected. The negative edge clocks data from the SFP transceiver. The serial data signal (SDA, Mod Def 2) is bi-directional for serial data transfer. The host uses SDA in conjunction with SCL to mark the start and end of serial protocol activation. The memories are organized as a series of 8-bit data words that can be addressed individually or sequentially.

For more information, please see the SFP MSA documentation^{cf} and Finisar Application Note AN- 2030.

IX. Digital Diagnostic Specifications

FTLF8532P4BCV transceivers can be used in host systems that require either internally or externally calibrated digital diagnostics.

Parameter	Symbol	Min	Max	Units	Ref.
Accuracy					
Internally measured transceiver temperature	DD _{Temp}		±5	°C	
Internally measured transceiver supply voltage	DD _{Voltage}		±100	mV	
Measured TX bias current	DD _{Bias}		±10	%	1
Measured TX output power	DD _{Tx-Power}		±2	dB	
Measured RX received average optical power	DD _{Rx-Power}		±2	dB	
Dynamic Range for Rated Accuracy					
Internally measured transceiver temperature	DD _{Temp}	-5	85	°C	
Internally measured transceiver supply voltage	DD _{Voltage}	3.14	3.46	V	
Measured TX bias current	DD _{Bias}	0	20	mA	
Measured TX output power	DD _{Tx-Power}	-5	-1	dBm	
Measured RX received average optical power	DD _{Rx-Power}	-20	0	dBm	
Max Reporting Range					
Internally measured transceiver temperature	DD _{Temp}	-10	90	°C	
Internally measured transceiver supply voltage	DD _{Voltage}	2.8	4.0	V	
Measured TX bias current	DD _{Bias}	0	20	mA	
Measured TX output power	DD _{Tx-Power}	-10	-1	dBm	
Measured RX received average optical power	DD _{Rx-Power}	-22	0	dBm	

Notes:

1. Accuracy of Measured Tx Bias Current is 10% of the actual Bias Current from the laser driver to the laser

X. Mechanical Specifications

Finisar FTLX8574D3BNL SFP+ transceivers are compatible with the SFF-8432 specification for improved pluggable form factor, and shown here for reference purposes only. Bail color is beige.

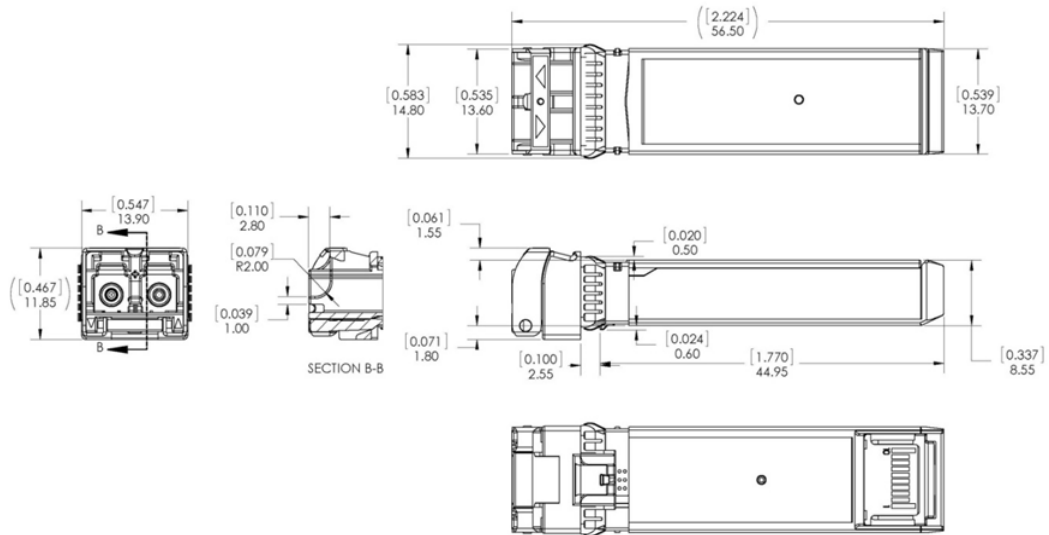

Figure 2. FTLX8574D3BNL Mechanical Dimensions and Tolerances.

XI. PCB Layout and Bezel Recommendations

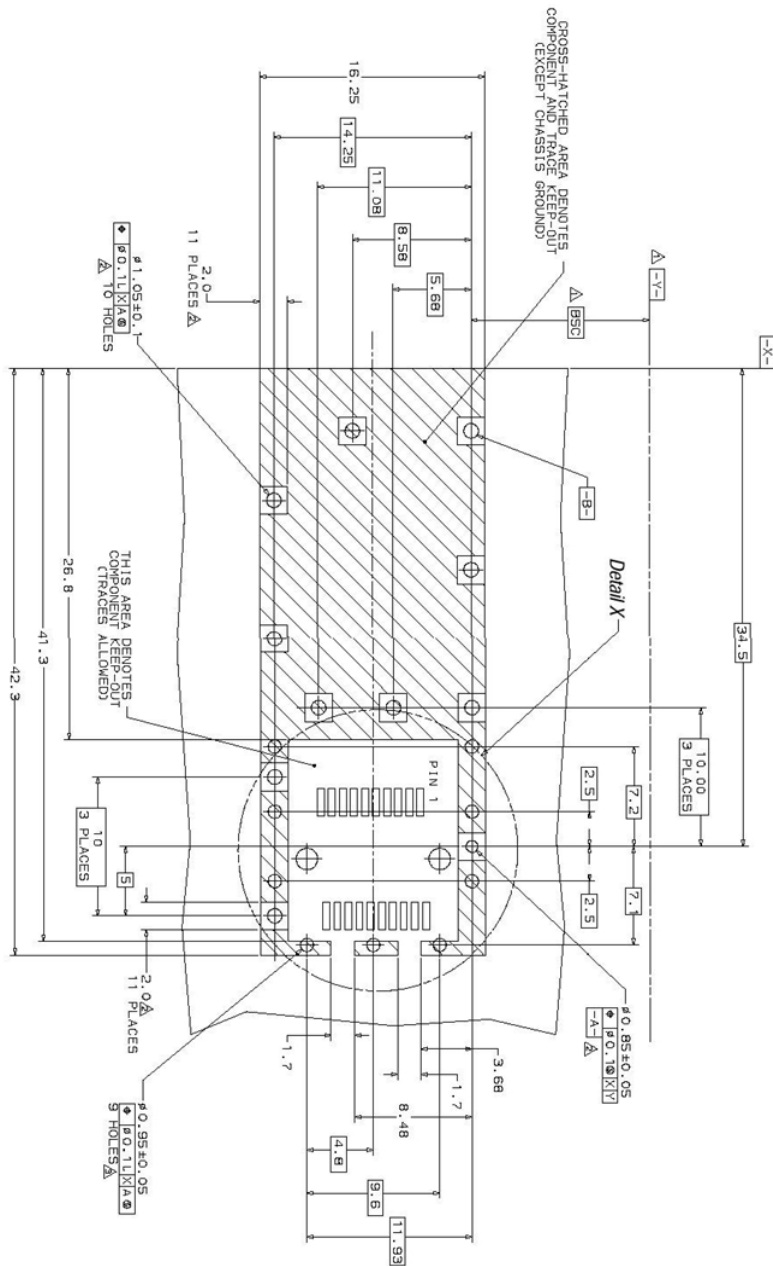
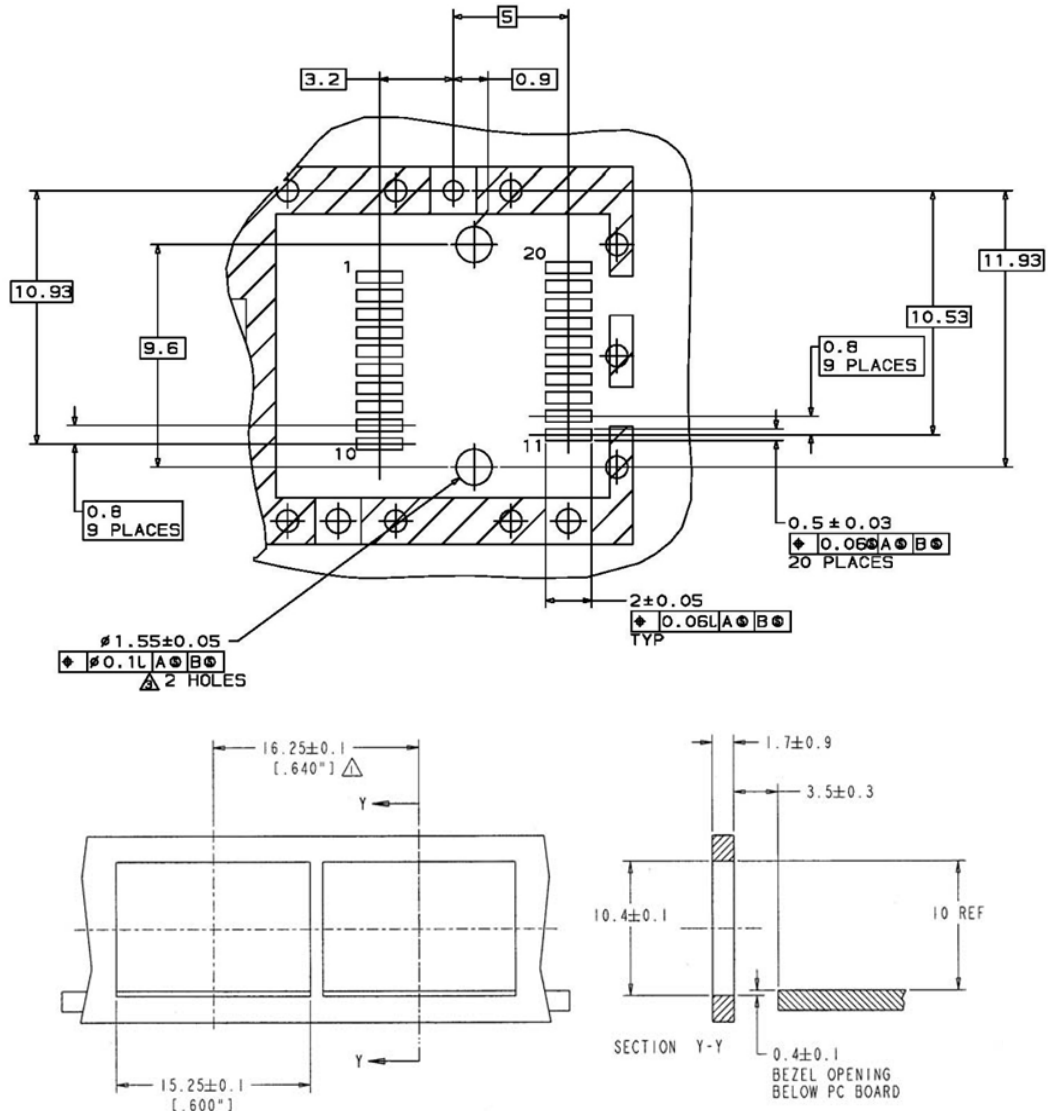

Figure 3.

- △ Datum and Basic Dimension Established by Customer
- ▮ Rads and Vias are Chassis Ground, 11 Places
- △ Through Holes are Unplated



- NOTES:
- △ MINIMUM PITCH ILLUSTRATED, ENGLISH DIMENSIONS ARE FOR REFERENCE ONLY
 2. NOT RECOMMENDED FOR PCI EXPANSION CARD APPLICATIONS

Figure 4.

XII. Host - Transceiver Interface Block Diagram

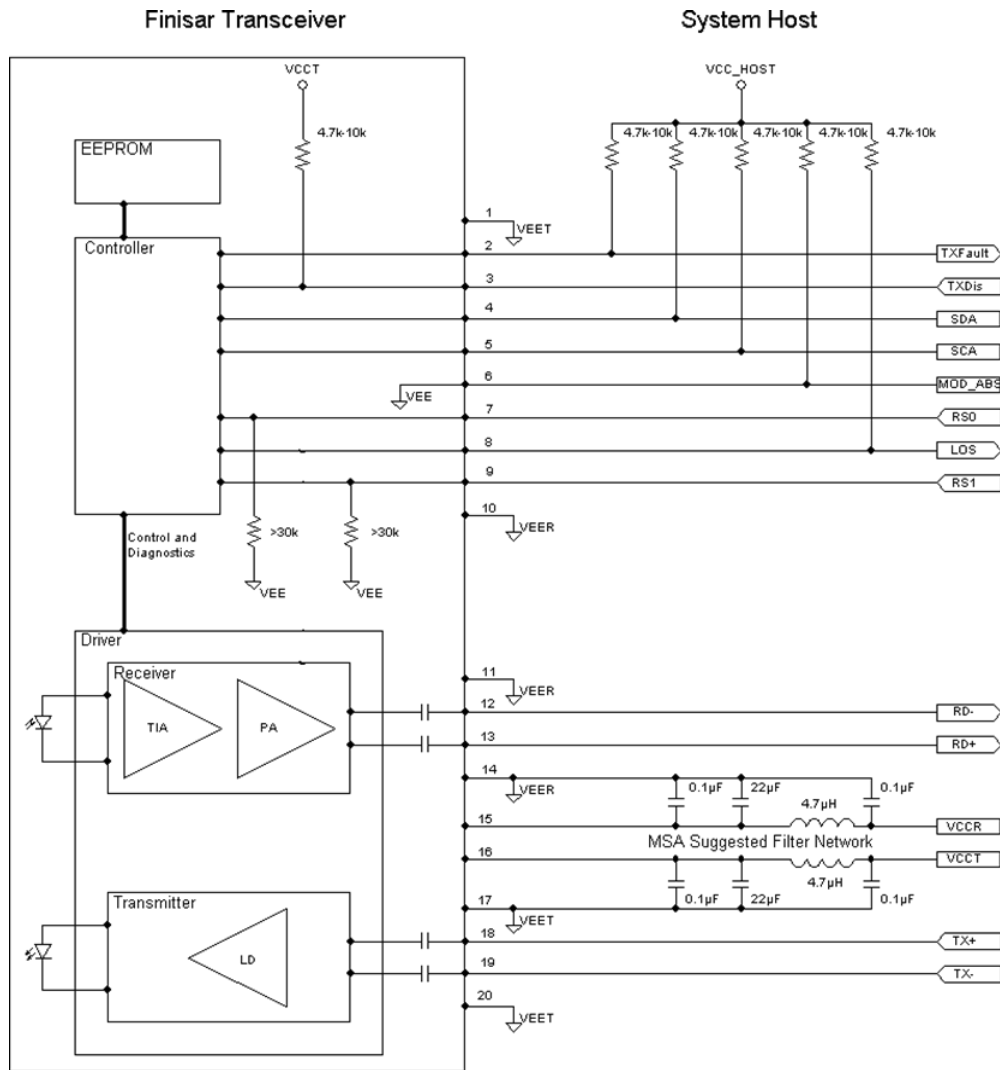

Figure 5. Host-Module Interface

XIII. References

1. "Specifications for Enhanced 8.5 and 10 Gigabit Small Form Factor Pluggable Module 'SFP+'", SFF Document Number SFF-8431, Revision 4.1.
2. "Improved Pluggable Formfactor", SFF Document Number SFF-8432, Revision 5.0.
3. IEEE Std 802.3, Clause 52, PMD Type 10GBASE-SR. IEEE Standards Department.
4. American National Standard for Information Technology - Fibre Channel - 10 Gigabit Fibre Channel, Rev 3.5, April 9, 2003.
5. "Digital Diagnostics Monitoring Interface for Optical Transceivers". SFF Document Number SFF-8472, Revision 11.1.
6. Directive 2011/65/EC of the European Council Parliament and of the Council, "on the restriction of the use of certain hazardous substances in electrical and electronic equipment".
7. "Application Note AN-2038: Finisar Implementation Of RoHS Compliant Transceivers".