

# FTLX6873MTC

## 10Gb/s DWDM 80km Multi-Rate Tunable SFP+ Transceiver Industrial temp

FTLX6873MTC transceivers are Enhanced Small Form Factor Pluggable Tunable SFP+ transceivers designed for use in 10-Gigabit multi-rate links up to 80km of G.652 single mode fiber. They are compliant with SFF-8431<sup>1</sup>, SFF-8432<sup>2</sup>, SFF-86908, and G.698.1 DS100S1-2Dz(C), and support SONET OC-192, SDH STM-64, 10G Ethernet ZR and 10G Fibre Channel over 80km fiber. Digital diagnostics functions are available via a 2-wire serial interface, as specified in SFF-84723. The optical transceiver is RoHS compliant as described in Application Note AN-2038<sup>4,5</sup>.

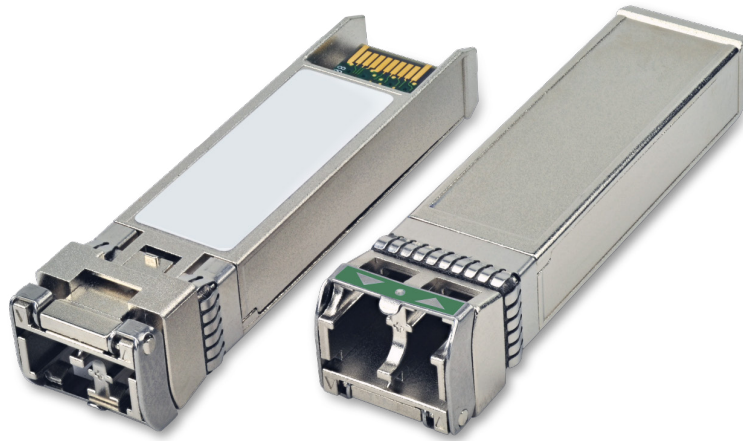

### FEATURES

- Hot-pluggable SFP+ footprint
- Supports 8.5 and 9.95 to 11.3 Gb/s
- Up to 80km link length
- 100GHz ITU-based channel spacing (C-Band)
- -40 /+85°C operating temperature range (-40C cold start)
- Single 3.3V power supply
- Monolithic MZM Tunable TOSA
- Limiting electrical interface APD receiver
- Duplex LC connector
- Built-in digital diagnostic functions
- RoHS compliant

### APPLICATIONS

- DWDM 80km point to point links:
- Remote PHY (R-PHY)
- Wireless Backhaul
- 10Gb/s SONET/SDH
- 10G Ethernet
- 8G/10G Fibre Channel
- ITU-T G.698.1 DS100S1-2Dz(C)
- ITU-T G.709

Product Selection

FTLX6873MTC

RX Interface: Limiting

I. Pin Descriptions

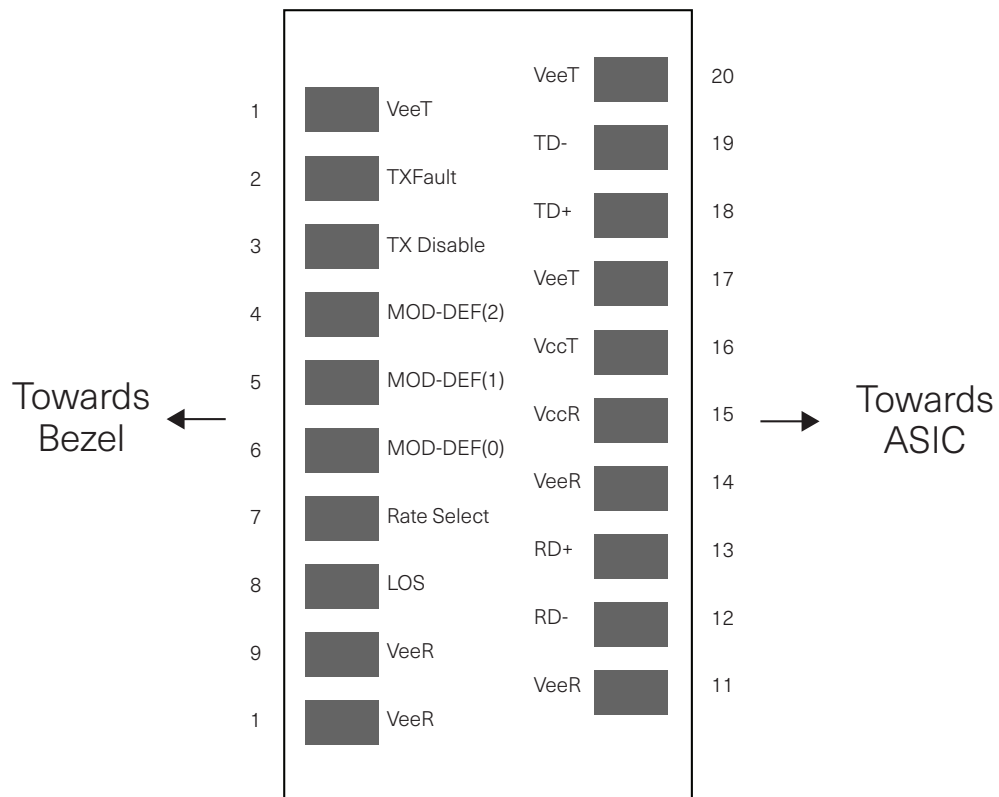

Diagram of Host Board Connector Block Pin Numbers and Names

Pin	Symbol	Name/Description	Notes
1	V <sub>EET</sub>	Transmitter Ground	1
2	T <sub>FAULT</sub>	Transmitter Fault	2
3	T <sub>DIS</sub>	Transmitter Disable. Laser output disabled on high or open.	3
4	SDA	2-wire Serial Interface Data Line	2
5	SCL	2-wire Serial Interface Clock Line	2
6	MOD_ABS	Module Absent. Grounded within the module	2
7	NA	Not Used	
8	RX_LOS	Loss of Signal indication. Logic 0 indicates normal operation.	4
9	NA	No Used	
10	V <sub>EER</sub>	Receiver Ground	1
11	V <sub>EER</sub>	Receiver Ground	1
12	RD-	Receiver Inverted DATA out. AC Coupled.	
13	RD+	Receiver Non-inverted DATA out. AC Coupled.	
14	V <sub>EER</sub>	Receiver Ground	1
15	V <sub>CCR</sub>	Receiver Power Supply	5
16	V <sub>CCT</sub>	Transmitter Power Supply	5
17	V <sub>EET</sub>	Transmitter Ground	1
18	TD+	Transmitter Non-Inverted DATA in. AC Coupled.	
19	TD-	Transmitter Inverted DATA in. AC Coupled.	
20	V <sub>EET</sub>	Transmitter Ground	1

- Notes
1. Circuit ground is internally isolated from chassis ground.
  2. T<sub>FAULT</sub> is an open collector/drain output, which should be pulled up with a 4.7k – 10k Ohms resistor on the host board if intended for use. Pull up voltage should be between 2.0V to V<sub>cc</sub> + 0.3V. A high output indicates a transmitter fault caused by either the TX bias current or the TX output power exceeding the preset alarm thresholds. A low output indicates normal operation. In the low state, the output is pulled to <0.8V.
  3. Laser output disabled on T<sub>DIS</sub> >2.0V or open, enabled on T<sub>DIS</sub> <0.8V.
  4. LOS is open collector output. Should be pulled up with 4.7k – 10kΩ on host board to a voltage between 2.0V and 3.6V. Logic 0 indicates normal operation; logic 1 indicates loss of signal.
  5. Internally connected

## II. Absolute Maximum Ratings

Exceeding the limits below may damage the transceiver module permanently.

Parameter	Symbol	Min	Typ	Max	Unit	Ref.
Maximum Supply Voltage	Vcc	-0.5		4.0	V	
Storage Temperature	T <sub>s</sub>	-40		85	°C	
Relative Humidity	RH	0		85	°C	1
Receiver Optical Damage Threshold	Rx <sub>Damage</sub>	5			dBm	

Notes:

1. Non Condensing

## III. Electrical Characteristics (T<sub>OP</sub> = -40 to 85 °C)

Parameter	Symbol	Min	Typ	Max	Unit	Ref.
Supply Voltage	Vcc	3.14		3.46		
Supply Current	Icc			800	mA	1
Module total power dissipation	P			2.5	W	2
<b>Transmitter</b>						
Input differential impedance	R <sub>i_n</sub>	80	100	120	Ω	
Differential data input swing	V <sub>in,pp</sub>	200		850	mV	3
Transmit Disable Voltage	V <sub>D</sub>	Vcc-0.8		Vcc	V	
Transmit Enable Voltage	V <sub>EN</sub>	Vee		Vee+ 0.8	V	
<b>Receiver</b>						
Output differential impedance	R <sub>out</sub>	80	100	120	Ω	
Differential data output swing (Rx input power -18dBm to -7dBm)	V <sub>out,pp</sub>	150		850	mV	4
Output rise time and fall time	T <sub>r</sub> , T <sub>f</sub>	28			ps	4,5
LOS asserted	V <sub>LOS A</sub>	Vcc-0.8		Vcc	V	
LOS de-asserted	V <sub>LOS D</sub>	Vee		Vee+0.8	V	
Power Supply Noise Tolerance	VccT/VccR	Per SFF-8431 Rev 4.1			mVpp	

Notes:

1. Compliant with the SFP+ Module Power Supply Requirements defined in [1], Tab. 8.
2. Maximum total power value is specified across the full temperature and voltage range.
3. Connected directly to TX data input pins.
4. Into 100Ω differential termination.
5. 20 – 80%. Measured with Module Compliance Test Board and OMA test pattern. Use of four 1's and four 0's sequence in the PRBS 9 is an acceptable alternative. SFF-8431 Rev 4.1.

IV. Optical Characteristics ( $T_{OP} = -40$  to  $85$  °C,  $V_{CC} = 3.14$  to  $3.46$  Volts)

Parameter	Symbol	Min	Typ	Max	Unit	Ref.
Transmitter (Tx)						
Average Launch Power	$P_{AVE}$	-1		+3	dBm	
Optical Wavelength (48 total wavelengths)	$\lambda_C$	As per ITU-T 694.1, 100GHz spacing 1528.77 to 1566.31; (191.4THz – 196.1THz)			nm	
Side-Mode Suppression Ratio	SMSR	30			dB	
Optical Extinction Ratio	ER	8.2			dB	
Average Launch power when Tx is OFF	$P_{OFF}$			-30	dBm	
Tx Jitter 20kHz - 80MHz	$Tx_{j1}$			0.3	UI	
Tx Jitter 4MHz - 80MHz	$Tx_{j2}$			0.1	UI	
Relative Intensity Noise	RIN			-128	dB/Hz	
Center Wavelength	Beginning of Life	$\lambda_{CBOL}$	z-6.25	z	z+6.25	Pm
	End of Life	$\lambda_{CEOL}$	z-12.5	z	z+12.5	Pm
Receiver (Rx)						
Bit rate	BER					
8.5, 9.95	<1E-12	$R_{SENS1}$		-24.0	dBm	1, 2
10.7 Gb/s	<1E-12	$R_{SENS2}$		-23.0	dBm	1, 2
Overload (Average Power)	$P_{AVE}$			-7	dBm	
Optical Center Wavelength	$\lambda_C$	1260		1600	dBm	
LOS De-Assert	$LOS_D$			-25	dBm	
LOS Assert	$LOS_A$	-34		-27	dB	
LOS Hysteresis	$LOS_H$	0.5				
Receiver Reflectance	$R_{rx}$			-27		
Receiver Sensitivity <sup>3</sup>						
Data rate (Gb/s)	BER	Dispersion (ps/nm)	Sensitivity across Dispersion Range at OSNR>30dB (dBm)			
9.95	1e-12	-300 to 1450	-22			
10.3	1e-12	-300 to 1450	-21			

## Notes:

1. Measured with worst ER=8.2dB; BER<10<sup>-12</sup>; 2<sup>31</sup> – 1 PRBS.
2. For 10G Ethernet application, -24dBm is equivalent to an OMA of -22.09dBm for an ER = 8.2 dB.
3. Measured at 1528-1600nm with worst ER; PRBS31.

## V. General Specifications

Parameter	Symbol	Min	Typ	Max	Unit	Ref.
Bit Rate	BR	8.5		11.3168	Gb/s	1
Max. Supported Link Length	$L_{MAX}$			80	km	2

Notes:

1. Tested with a  $2^{31} - 1$  PRBS pattern at the BER defined in Table IV.
2. Over G.652 single mode fiber.

## VI. Timing Parameters

Parameter	Symbol	Min	Max	Unit	Ref.
Time to initialize cooled module	$t_{start\_up\_cooled}$		90*	s	

\* applies for temperatures above -20°C; see Section VII for timing below -20°C

## VII. Environmental Specifications

FTLX6873MTC transceivers have an operating temperature range from -40°C to +85°C.

Environmental Specifications	Symbol	Min	Typ	Max	Units	Ref.
Case Operating Temperature	$T_{op}$	-20		85	°C	3
Storage Temperature	$T_{sto}$	-40		85	°C	

Note:

3. For start-up case temperatures below -20°C, the module airflow is assumed to be 0 ft/s and the time to reach stabilized output power and wavelength will be less than 5 minutes.

## VII. Regulatory Compliance

Finisar transceivers are Class 1 Laser Products and comply with US FDA regulations. These products are certified by TÜV and CSA to meet the Class 1 eye safety requirements of EN (IEC) 60825 and the electrical safety requirements of EN (IEC) 60950. Copies of certificates are available at Finisar Corporation upon request.

## VIII. Digital Diagnostic Functions

FTLX6873MTC Tunable SFP+ transceivers support the 2-wire serial communication protocol as defined in the SFP MSA<sup>1</sup>. It is very closely related to the memory map defined in the GBIC standard, with the same electrical specifications.

The standard SFP serial ID provides access to identification information that describes the transceiver's capabilities, standard interfaces, manufacturer, and other information.

Additionally, Finisar® T-SFP+ transceivers provide an enhanced digital diagnostic monitoring interface, which allows real-time access to device operating parameters such as transceiver temperature, laser bias current, transmitted optical power, received optical power and transceiver supply voltage. It also defines a sophisticated system of alarm and warning flags, which alerts end-users when particular operating parameters are outside of a factory set normal range.

The SFP MSA defines a 256-byte memory map that is accessible over a 2-wire serial interface at the 8 bit address 1010000X (A0h). The digital diagnostic monitoring interface makes use of the 8 bit address 1010001X (A2h), so the originally defined serial ID memory map remains unchanged. The interface is identical to, and is thus fully backward compatible with both the GBIC Specification and the SFP Multi Source Agreement.

The operating and diagnostics information is monitored and reported by a Digital Diagnostics Transceiver Controller (DDTC) inside the transceiver, which is accessed through a 2-wire serial interface. When the serial protocol is activated, the serial clock signal (SCL, Mod Def 1) is generated by the host. The positive edge clocks data into the SFP transceiver into those segments of the E<sup>2</sup>PROM that are not write-protected. The negative edge clocks data from the SFP transceiver. The serial data signal (SDA, Mod Def 2) is bi-directional for serial data transfer. The host uses SDA in conjunction with SCL to mark the start and end of serial protocol activation. The memories are organized as a series of 8-bit data words that can be addressed individually or sequentially.

### IX. Digital Diagnostic Specifications

FTLX6873MTC transceivers can be used in host systems that require either internally or externally calibrated digital diagnostics.

Parameter	Symbol	Min	Max	Accuracy	Units	Ref.
Transceiver temperature	$\Delta DD_{DDTemp}$	-45	+90	$\pm 5^{\circ}C$	$^{\circ}C$	1
Transceiver supply voltage	$\Delta DD_{DDVoltage}$	2.8	4.0	$\pm 3\%$	V	
Transmitter bias current	$\Delta DD_{DDBias}$	0	127	$\pm 10\%$	mA	2
Transmitter output power	$\Delta DD_{DDTx-Power}$	-1	+5	$\pm 2dB$	dBm	
Receiver average optical input power	$\Delta DD_{DDRx-Power}$	-28	-5	$\pm 2dB$	dBm	

Notes:

- Internally measured
- The accuracy of the Tx bias current is 10% of the actual current from the laser driver to the laser

### X. Start-Up Sequence

FTLX6873MTC modules adhere to MSA SFF-8690 for wavelength / channel selection of these tunable modules. The module behavior is described in the flowchart below:

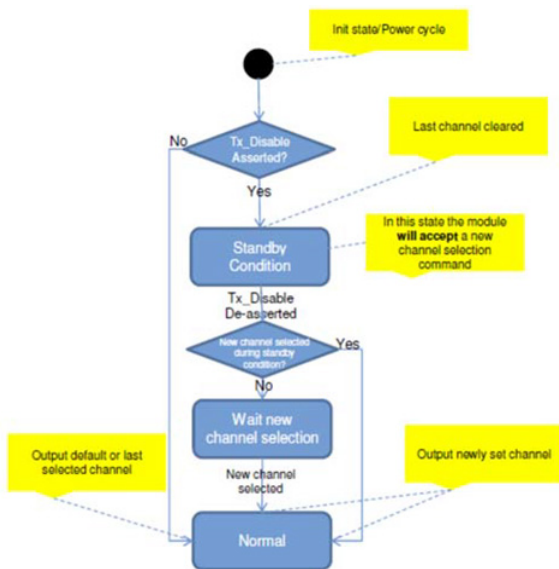



**Alarm and Warning Threshold Values (A2h)**

Address	Parameter	Threshold Values	UNITS
00-01	Temp High Alarm	90	C
02-03	Temp Low Alarm	-45	C
04-05	Temp High Warning	88	C
06-07	Temp Low Warning	-43	C
08-09	Voltage High Alarm	3.56	V
10-11	Voltage Low Alarm	3.04	V
12-13	Voltage High Warning	3.46	V
14-15	Voltage Low Warning	3.14	V
16-17	Bias High Alarm	130	mA
18-19	Bias Low Alarm	5	mA
20-21	Bias High Warning	120	mA
22-23	Bias Low Warning	10	mA
24-25	TX Power High Alarm	6.5	dBm
26-27	TX Power Low Alarm	-3	dBm
28-29	TX Power High Warning	6	dBm
30-31	TX Power Low Warning	-1.5	dBm
32-33	RX Power High Alarm	-4	dBm
34-35	RX Power Low Alarm	-31	dBm
36-37	RX Power High Warning	-5	dBm
38-39	RX Power Low Warning	-25	dBm
40-55	Reserved		

**XI. The FTLX6872MTC modules do not contain Internal CDRs.****XII. SFF-8431 Power-up Sequence**

The typical power consumption of the FTLX6873MTC exceeds the limit of 1.5W specified in the SFF-8431 for the Power Level II device, for which the SFF-8431 recommends a power-up sequence. Per the SFF-8431, at the power-on a Power Level II transceiver can stay in Power Level I until the host enables the transceiver to complete its power-up sequence, reaching its operating power consumption into Power Level Mode II. Please refer to SFF-8431 and Application Note AN-2076<sup>7</sup> for additional details.

The FTLX6873MTC is factory set to power-up directly to its operating conditions in Power Level Mode II. Upon request, it can be factory set to follow the above power-up sequence at the power-on. In power level I, the FTLX6873MTC does not carry traffic, but the 2-wire serial communication is active.

**XIII. Mechanical Specifications**

FTLX6873MTC SFP+ transceivers are compatible with the SFF-8432 specification for improved pluggable form factor, and shown here for reference purposes only. Bail color is green.

ITEM	DIM (mm)	TOL (mm)
A	9.00	±0.3
B	9.60	±0.5
C	11.90	±0.5
D	13.85	±0.15
E	13.65	±0.15
F	2.80	±0.2
G	1.00	±0.2
H	4.00	REF
J	2.00	±0.2
K	56.50	REF
L	1.60	±0.5
M	2.25	±0.1
N	1.80	±0.1
P	37.10	±0.3
Q	9.15	±0.15
R	1.00	±0.1
S	8.55	±0.15
T	47.50	±0.2
V	2.55	±0.1
W	43.00	±0.2
X	14.70	±0.5
Z	0.55	±0.15

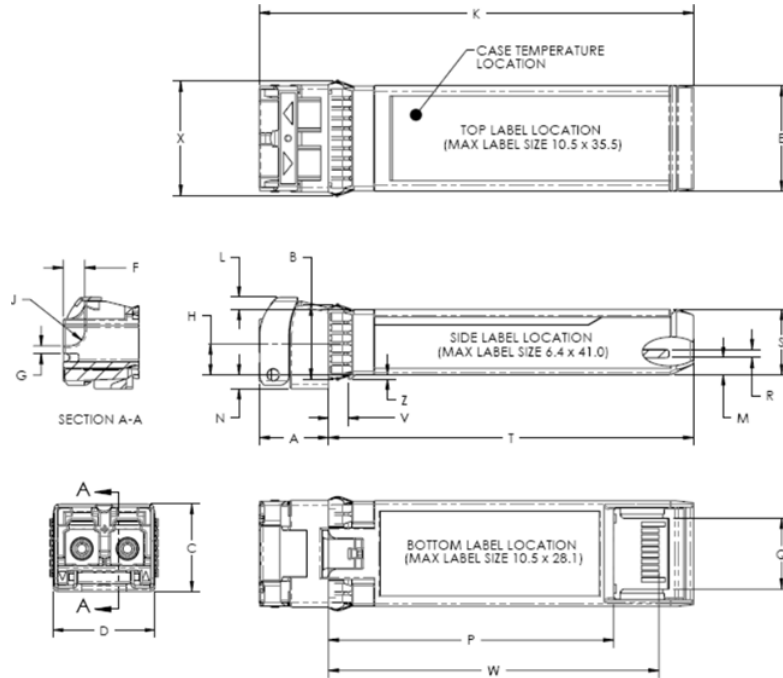





Figure 2. Mechanical Dimensions

Connector Recommendations

**Product Label and Box Label**

These are “subject to change without notice” and being used as a guideline for the format.

<p>S/N: R01H1002</p> <p><b>FINISAR</b></p>  <p>Class 1 21CFR1040.10</p> <p>LI#50 06/2007</p> <p>FTLX6873MTC</p> <p>MADE IN CHINA</p>	<p><b>FINISAR</b></p> <p>T-SFP+</p> <p>Model: FTLX6873MTC</p>  <p>S/N: R01H1002</p>  <p>QTY: 1</p> <p>Made in China</p>
---	---

XIV. PCB Layout and Bezel Recommendations

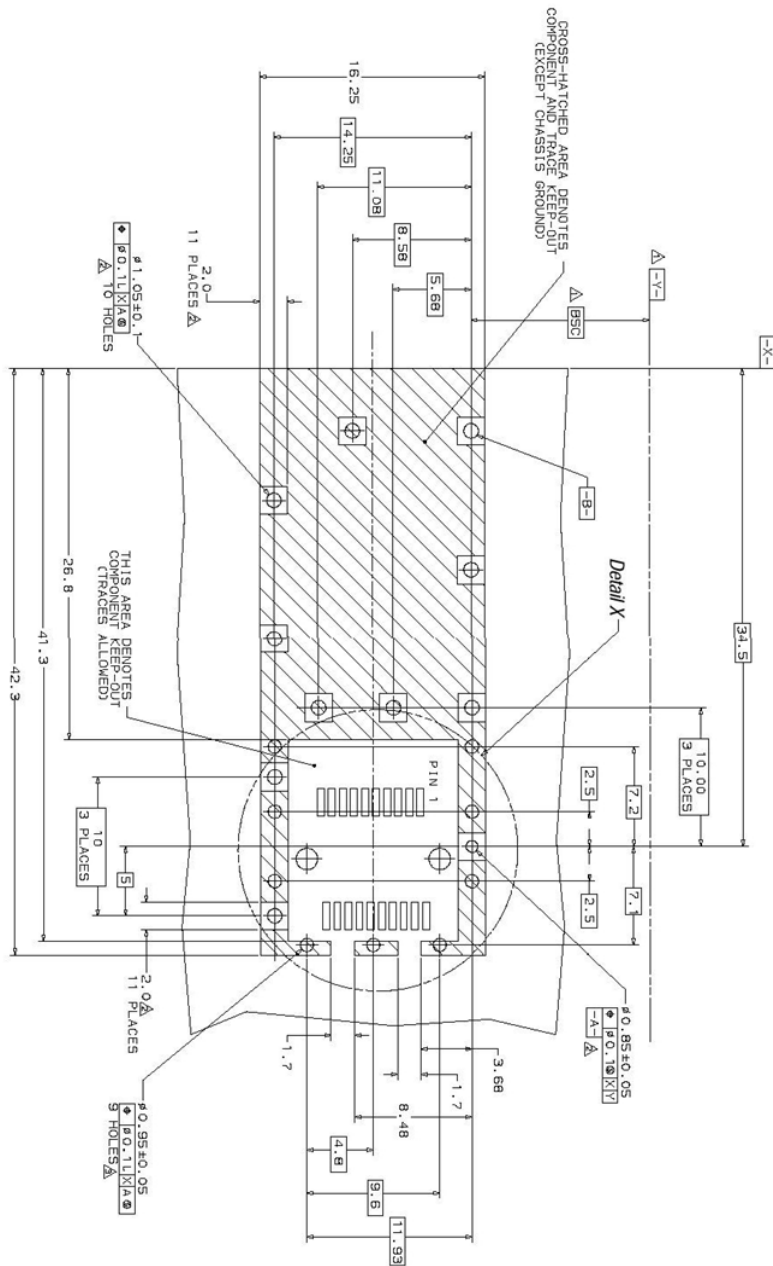
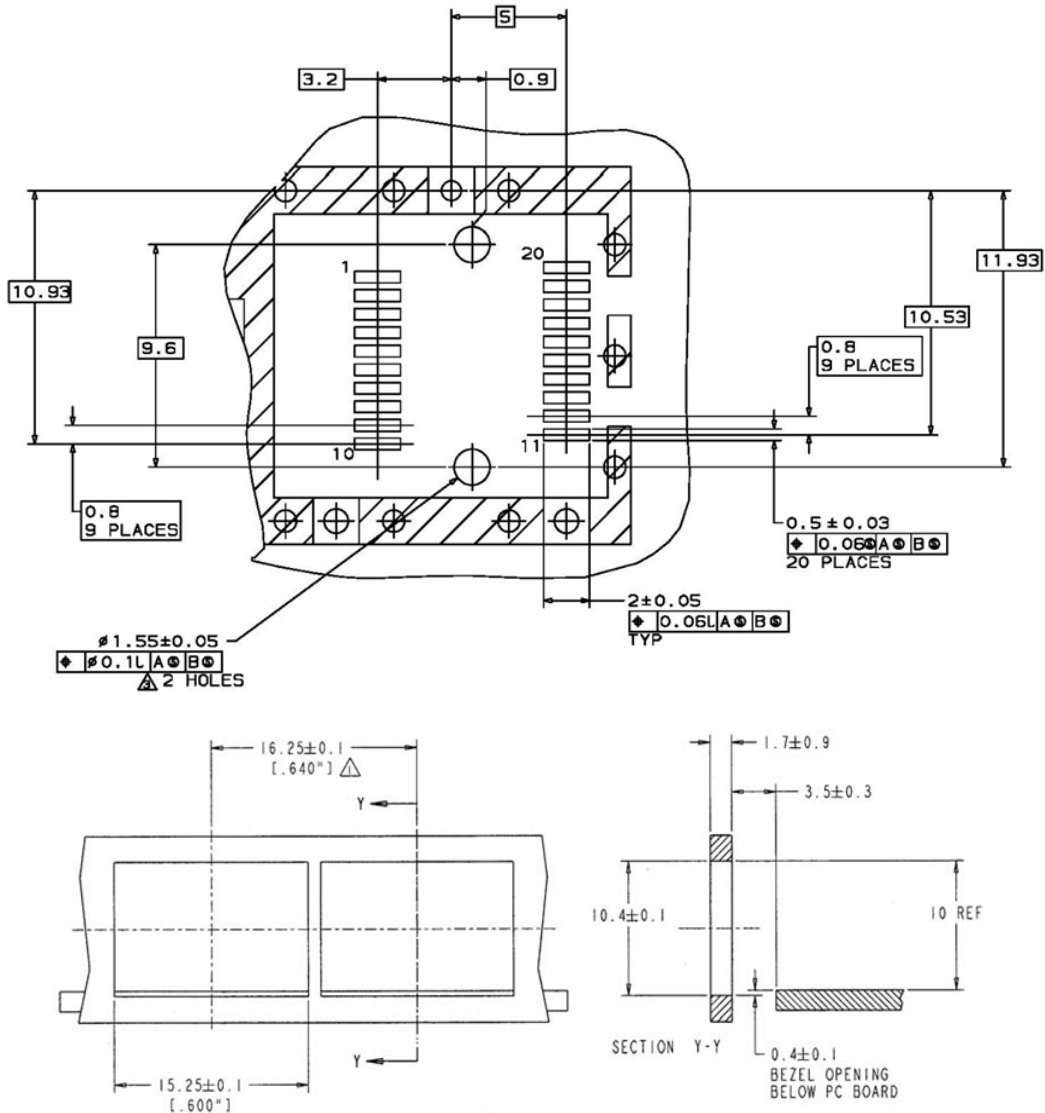

Figure 3. PCB Layout and Bezel Recommendations, as per [9]

- $\Delta$  Datum and Basic Dimension Established by Customer
- $\Delta$  Rads and Vias are Chassis Ground, 11 Places
- $\Delta$  Through Holes are Unplated



- NOTES:
1. MINIMUM PITCH ILLUSTRATED, ENGLISH DIMENSIONS ARE FOR REFERENCE ONLY
  2. NOT RECOMMENDED FOR PCI EXPANSION CARD APPLICATIONS

Figure 4.

**XV. Host-Module Interface Diagram**

To Be Provided in future release.  
Figure 5

**XVI. References**

1. "Specifications for Enhanced 8.5 and 10 Gigabit Small Form Factor Pluggable Module 'SFP+ '", SFF Document Number SFF-8431, Revision 4.1 (or later).
2. "Improved Pluggable Form factor", SFF Document Number SFF-8432, Revision 4.2, April 18, 2007 (or later).
3. "Digital Diagnostics Monitoring Interface for Optical Transceivers". SFF Document Number SFF-8472, Revision 11.3, (or later).
4. Directive 2011/65/EU of the European Council Parliament and of the Council, "on the restriction of the use of certain hazardous substances in electrical and electronic equipment" as well as Commission Delegated Directive (EU) 2015/863 amending Annex II to Directive 2011/65/EU. Certain products may use one or more exemptions as allowed by the Directive.
5. "Application Note AN-2038: Finisar Implementation of RoHS Compliant Transceivers", Finisar Corporation, January 21, 2005.
6. Small Form-factor Pluggable (SFP) Transceiver Multi-Source Agreement (MSA)
7. "Application Note AN-2076: SFP+ Level II Power Up Sequence", Rev B
8. Tunable SFP+ MSA; SFF-8690

**XVII. Revision History**

Revision	Date	Description
A00	December 2019	Initial Release
B01	March 2020	Updated to II-VI template
B02	July 2020	Updated regulatory statements; updated sensitivity requirements