

FTLF8540P4BCL

25.78Gb/s RoHS Compliant Extended Short Wavelength SFP28 Transceiver

FTLF8540P4BCL SFP28 transceivers are designed for use in 25Gb/s data rate over multimode fiber. They are compliant to SFF-8472 Rev 12.1b and SFF-8402g, and compatible with SFF-8432a and applicable portions of SFF-8431 Rev. 4.1c. The transceiver is RoHS compliant and per Directive 2011/65/EUd . See Finisar Application Note AN-2038 for more details.



FEATURES

- Up to 25.78 Gb/s bi-directional data links
- Hot-pluggable SFP+ footprint
- Built-in digital diagnostic functions
- 850nm Oxide VCSEL laser transmitter
- Duplex LC connector
- RoHS compliant
- 300m over OM4 MMF
- 200m over OM3 MMF
- Metal enclosure, for lower EMI
- 1.2W maximum power consumption
- Single 3.3V power supply
- Operating temperature range: 0°C to 70°C

APPLICATIONS

- 25.78 Gb/s single lane 100GE SR4
- 25.78 Gb/s single lane 100GE eSR4 in the break out application

Product Selection

FTLF8540P4BCL

I. Pin Descriptions

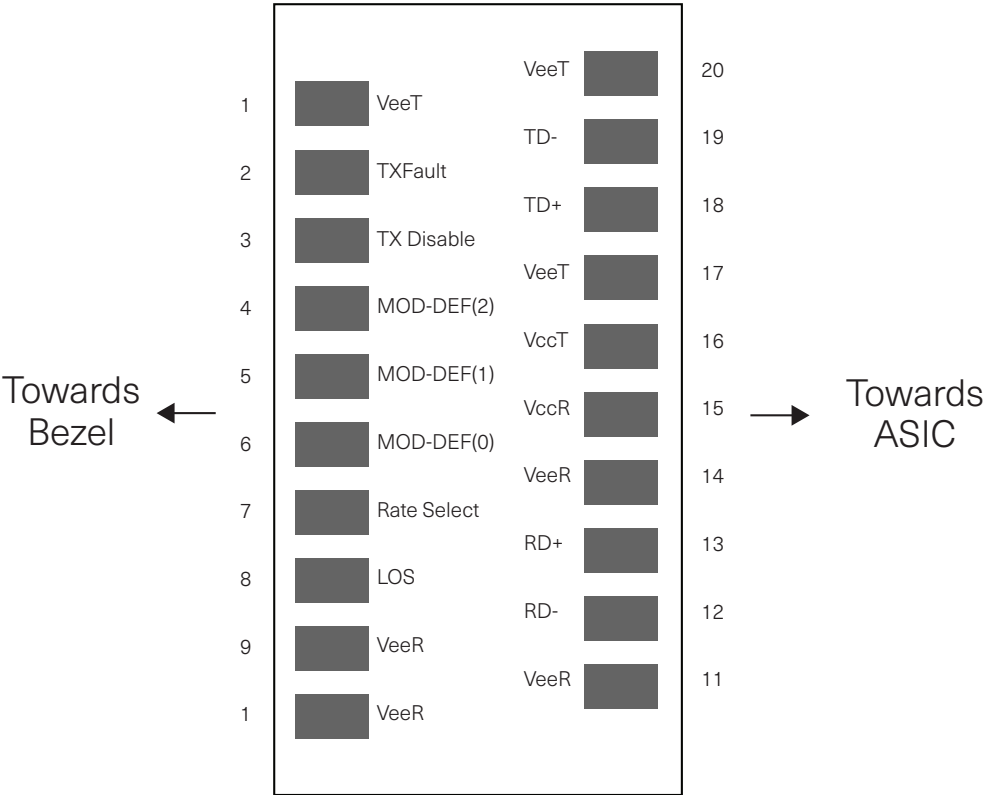

Diagram of Host Board Connector Block Pin Numbers and Names

Pin	Symbol	Name/Description	Notes
1	V _{EET}	Transmitter Ground (Common with Receiver Ground)	1
2	T _{FAULT}	Transmitter Fault.	2
3	T _{DIS}	Transmitter Disable. Laser output disabled on high or open.	3
4	SDA	2-wire Serial Interface Data Line (MOD-DEF2)	4
5	SCL	2-wire Serial Interface Clock (MOD-DEF1)	4
6	MOD_ABS	Module Absent, connected to VEET or VEER	4
7	RS0	NC	5
8	RX_LOS	Loss of Signal indication. Logic 0 indicates normal operation.	6
9	RS1	NC	5
10	V _{EER}	Receiver Ground (Common with Transmitter Ground)	1
11	V _{EER}	Receiver Ground (Common with Transmitter Ground)	1
12	RD-	Receiver Inverted DATA out. AC Coupled	
13	RD+	Receiver Non-inverted DATA out. AC Coupled	
14	V _{EER}	Receiver Ground (Common with Transmitter Ground)	1
15	V _{CCR}	Receiver Power Supply	
16	V _{CCT}	Transmitter Power Supply	
17	V _{EET}	Transmitter Ground (Common with Receiver Ground)	1
18	TD+	Transmitter Non-Inverted DATA in. AC Coupled.	
19	TD-	Transmitter Inverted DATA in. AC Coupled.	
20	V _{EET}	Transmitter Ground (Common with Receiver Ground)	1

- Notes
- Circuit ground is internally isolated from chassis ground.
 - T_{FAULT} is an open collector/drain output, which should be pulled up with a 4.7k – 10k Ohms resistor on the host board if intended for use. Pull up voltage should be between 2.0V to V_{cc} + 0.3V. A high output indicates a transmitter fault caused by either the TX bias current or the TX output power exceeding the preset alarm thresholds. A low output indicates normal operation. In the low state, the output is pulled to <0.8V.
 - Laser output disabled on T_{DIS} >2.0V or open, enabled on T_{DIS} <0.8V.
 - Should be pulled up with 4.7k – 10kohms on host board to a voltage between 2.0V and 3.6V. MOD_ABS pulls line low to indicate module is plugged in.
 - Rate select is not used.
 - LOS is open collector output. Should be pulled up with 4.7k – 10kohms on host board to a voltage between 2.0V and 3.6V. Logic 0 indicates normal operation; logic 1 indicates loss of signal.

II. Absolute Maximum Ratings

Parameter	Symbol	Min	Typ	Max	Unit	Ref.
Maximum Supply Voltage	V _{cc}	-0.5		4.0	V	
Storage Temperature	T _s	-40		85	°C	
Case Operating Temperature	T _c	0		70	°C	
Relative Humidity (Non-condensing)	RH	0		85	dBm	1

- Notes:
- Non-condensing.

III. Electrical Characteristics (T_A , $V_{CC} = 3.15$ to 3.46 Volts)

Parameter	Symbol	Min	Typ	Max	Unit	Ref.
Supply Voltage	V_{CC}	3.15		3.46	V	
Supply Current	I_{CC}			350	mA	1
Transmitter						
Input differential impedance	R_{in}		100		Ω	2
Differential data input swing	$V_{in,pp}$	90		800	mV	
Transmit Disable Voltage	V_D	2		V_{CC}	V	3
Transmit Enable Voltage	V_{EN}	Vee		Vee+0.8	V	
Receiver						
Single ended data output swing	$V_{out,pp}$	185		425	mV	4
LOS Fault	$V_{LOS\ fault}$	2		$V_{CC_{HOST}}$	V	5
LOS Normal	$V_{LOS\ norm}$	Vee		Vee+0.8	V	5
Power Supply Rejection	PSR	100			mVpp	6

Notes:

1. With established link. The total power dissipation could exceed 1W when the module is trying to establish link at operating case temperature below 25oC
2. Connected directly to TX data input pins. AC coupling from pins into laser driver IC.
3. Or open circuit.
4. Into 100 ohms differential termination.
5. LOS is an open collector output. Should be pulled up with 4.7k – 10kohms on the host board. Normal operation is logic 0; loss of signal is logic 1. Maximum pull-up voltage is 5.5V.
6. Receiver sensitivity is compliant with power supply sinusoidal modulation of 20 Hz to 1.5 MHz up to specified value applied through the recommended power supply filtering network.

IV. Optical Characteristics ($T_A V_{CC3} = 3.14$ to 3.46 Volts)

Parameter	Symbol	Min	Typ	Max	Unit	Ref.
Transmitter						
Average Output Power: 50 or 62.5 MMF	P_{OUT}	-8.4		2.4	dBm	1
Optical Wavelength	λ	840		860	nm	
Spectral Width (RMS)	σ			0.5	nm	
Optical Modulation Amplitude	TxOMA	-4.3		3	dBm	
Transmitter and Dispersion Eye Closure	TDEC			4.3	dB	
Relative Intensity Noise	RIN			-136	dB/Hz	
Extinction Ratio	ER	2				
Receiver						
Stressed Receiver OMA Sensitivity	RxSENS			-4.1	dBm	
Average Receiver Power	Rx_{MAX}	-11.9		3	dBm	
Optical Center Wavelength	λ_C	840		860	nm	
Optical Return Loss		12			dB	
LOS De-Assert	LOSD			-13	dBm	
LOS Assert	LOSA	-30			dBm	
LOS Hysteresis		0.5			dB	

Notes:

1. Class 1 Laser Safety limit per FDA/CDRH, and EN (IEC) 60825 laser safety standards.

V. General Specifications

Parameter	Symbol	Min	Typ	Max	Unit	Ref.
Data Rate	BR		25.78		Gb/sec	
Bit Error Rate	BER			5E (-5)		
Fiber Length on 50/125 μ m high- bandwidth (OM4) MMF	L			300	m	

VII. Environmental Specifications

Environmental Specifications	Symbol	Min	Typ	Max	Units	Ref.
Case Operating Temperature	T_{op}	0		70	$^{\circ}$ C	
Storage Temperature	T_{sto}	-40		85	$^{\circ}$ C	

VII. Regulatory Compliance

Finisar transceivers are Class 1 Laser Products and comply with US FDA regulations. These products are certified by TÜV and CSA to meet the Class 1 eye safety requirements of EN (IEC) 60825 and the electrical safety requirements of EN (IEC) 60950. Copies of certificates are available at Finisar Corporation upon request.

CAUTION – Use of Controls or adjustments or performance of procedures other than those specified herein may result in hazardous radiation exposure

VIII. Digital Diagnostic Functions

Finisar FTLF8540P4BCL SFP28 transceivers support the 2-wire serial communication protocol as defined in the SFP MSA¹. It is very closely related to the E²PROM defined in the GBIC standard, with the same electrical specifications.

The standard SFP serial ID provides access to identification information that describes the transceiver's capabilities, standard interfaces, manufacturer, and other information.

Additionally, Finisar SFP transceivers provide an enhanced digital diagnostic monitoring interface, which allows real-time access to device operating parameters such as transceiver temperature, laser bias current, transmitted optical power, received optical power and transceiver supply voltage. It also defines a sophisticated system of alarm and warning flags, which alerts end-users when particular operating parameters are outside of a factory set normal range.

The SFP MSA defines a 256-byte memory map in E²PROM that is accessible over a 2-wire serial interface at the 8 bit address 1010000X (A0h). The digital diagnostic monitoring interface makes use of the 8 bit address 1010001X (A2h), so the originally defined serial ID memory map remains unchanged. The interface is identical to, and is thus fully backward compatible with both the GBIC Specification and the SFP Multi Source Agreement. The complete interface is described in Finisar Application Note AN-2030: "Digital Diagnostics Monitoring Interface for SFP Optical Transceivers".

The operating and diagnostics information is monitored and reported by a Digital Diagnostics Transceiver Controller (DDTC) inside the transceiver, which is accessed through a 2-wire serial interface. When the serial protocol is activated, the serial clock signal (SCL, Mod Def 1) is generated by the host. The positive edge clocks data into the SFP transceiver into those segments of the E²PROM that are not write-protected. The negative edge clocks data from the SFP transceiver. The serial data signal (SDA, Mod Def 2) is bi-directional for serial data transfer. The host uses SDA in conjunction with SCL to mark the start and end of serial protocol activation. The memories are organized as a series of 8-bit data words that can be addressed individually or sequentially.

For more information, please see the SFP MSA documentation^{c,f} and Finisar Application Note AN- 2030.

TX Equalization Control

Tx input equalization control can be accessed through 2-wire serial interface at byte address 114 (A2h). Tx input equalization control for 25GE is located at the upper 4 bits of byte 114 (A2h) while the lower 4 bits are reserved for rate low in the case of dual rate application.

RX Emphasis Control

Rx output emphasis control can be accessed through 2-wire serial interface at byte address 115 (A2h). Rx output emphasis control for 25GE is located at the upper 4 bits of byte 115 (A2h) while the lower 4 bits are reserved for rate low in the case of dual rate application.

IX. Digital Diagnostic Specifications

FTLF8540P4BCL transceivers can be used in host systems that require either internally or externally calibrated digital diagnostics.

Parameter	Symbol	Units	Min	Max	Accuracy	Ref.
Transceiver temperature	D _{DDTemp}	°C	-10	80	±5°C	
Transceiver supply voltage	D _{DDVoltage}	%	2.8	4.0	±3%	
Transmitter bias current	D _{DDBias}	%	0	20	±10%	1
Transmitter output power	D _{DDTx-Power}	dB	-10	+2	±2dB	
Receiver average optical input power	D _{DDRx-Power}	dB	-22	+2	±2dB	

Notes:

1. Accuracy of Measured Tx Bias Current is 10% of the actual Bias Current from the laser driver to the laser.

XII. Mechanical Specifications

Finisar's FTLF8540P4BCL SFP28 transceivers are compatible with the SFF-8432b specification for improved pluggable form factor.

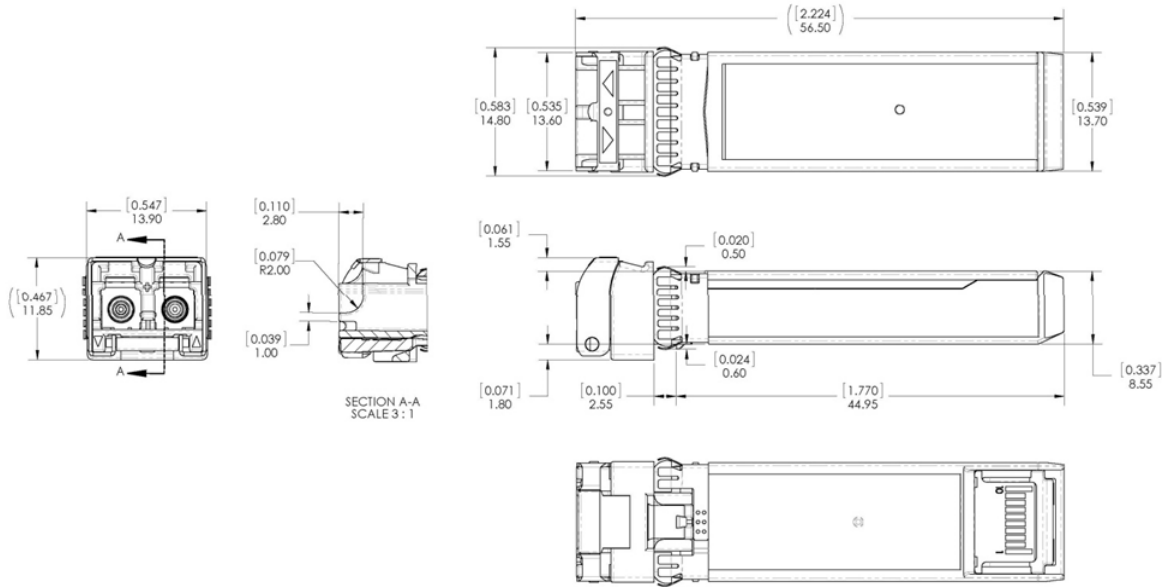

FTLF8540P4BCL

XIII. PCB Layout and Bezel Recommendations

- △ Datum and Basic Dimension Established by Customer
- △ Rads and Vias are Chassis Ground, 11 Places
- △ Through Holes are Unplated

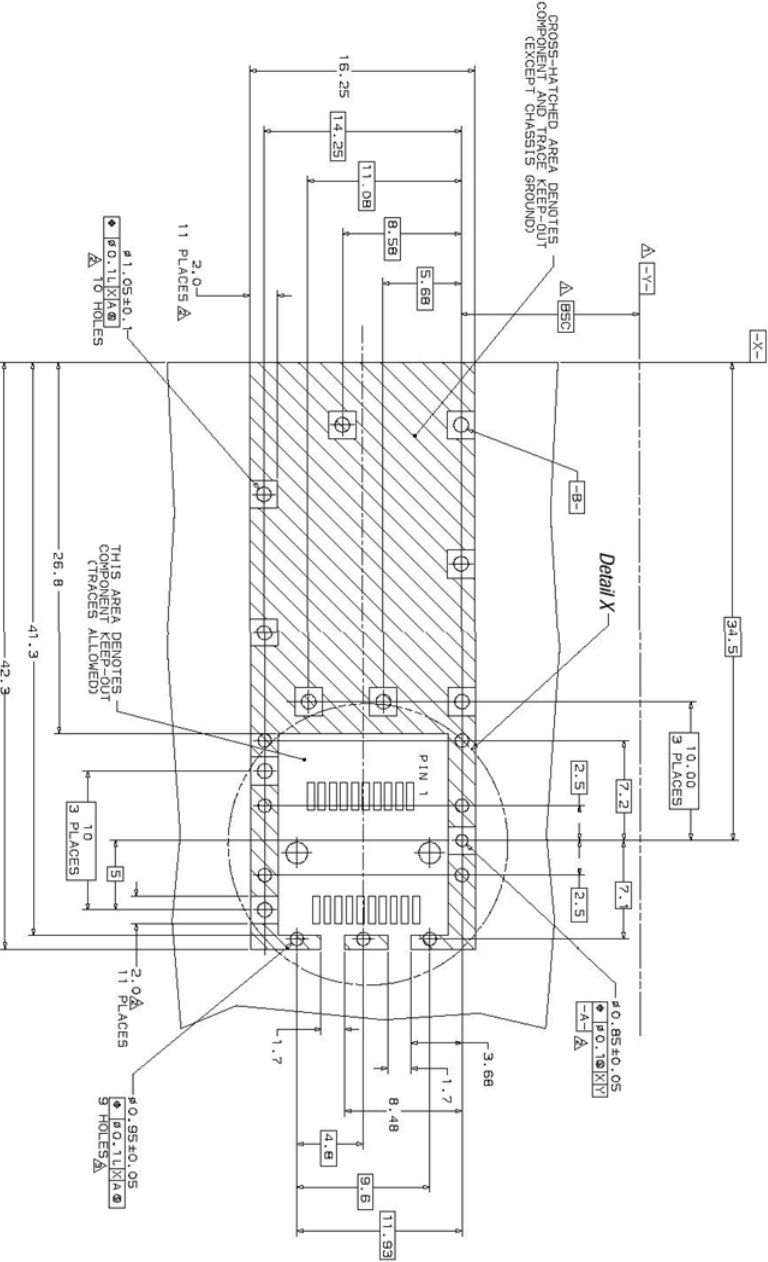
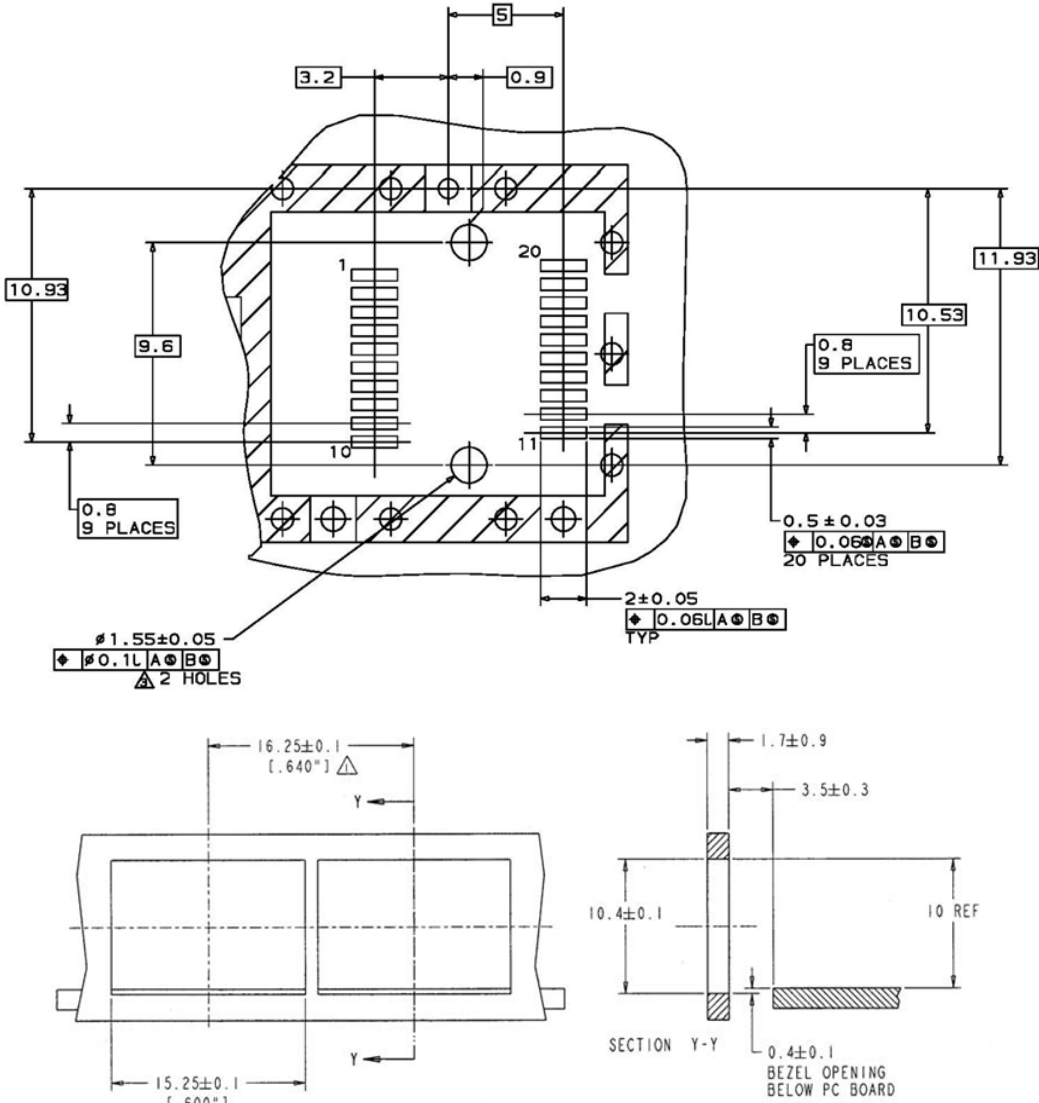

Figure 3. PCB Layout and Bezel Recommendations, as per [9]



- NOTES:
- 1. Δ MINIMUM PITCH ILLUSTRATED, ENGLISH DIMENSIONS ARE FOR REFERENCE ONLY
 - 2. NOT RECOMMENDED FOR PCI EXPANSION CARD APPLICATIONS

Figure 4.

XIV. References

- a. "Improved Pluggable Form Factor", SFF Document Number SFF-8432, Revision 5.0, July 16, 2007.
- b. "Digital Monitoring Interface for Optical Transceivers", SFF Document Number SFF-8472, Revision 12.1.
- c. "Enhanced Small Form Factor Pluggable Module 'SFP+'", SFF Document Number SFF-8431, Revision 4.1, July 6, 2009; Addendum Jun 21, 2013.
- d. Directive 2011/65/EU of the European Council Parliament and of the Council, "on the restriction of the use of certain hazardous substances in electrical and electronic equipment". 08-June 2011, which supersedes the previous ROHS Directive 2002/95/EC.
- e. Small Form Factor Pluggable (SFP) Transceiver Multi-source Agreement (MSA), September 14, 2000 which is available as SFF Document Number INF-8074, Revision 1.0 May 12, 2001
- f. "0.8mm Card Edge Connector for 16Gb/s Applications", SFF Document Number SFF-8081, Revision 0.2, December 21, 2009.
- g. SFF-8402, Revision 0.2