

FTLC9152RGPL

100m 100G QSFP28 SWDM4 Optical Transceiver

FTLC9152RGPL 100G QSFP28 transceiver modules are designed for use in 100G Ethernet links over duplex multimode fiber. They are compliant with the QSFP28MSA¹ and IEEE 802.3bm CAUI-4². Digital diagnostics functions are available via the I2C interface, as specified by the QSFP28 MSA¹ and Finisar Application Note AN_x005F_xFFFE_21715. The transceiver is RoHS-6 compliant per Directive 2011/65/EU³, and Finisar Application Note AN-2038⁴.



FEATURES

- Hot-pluggable QSFP28 form factor
- Supports 103.1Gb/s aggregate bit rate
- Power dissipation < 3.5W
- RoHS-6 compliant
- Commercial case temperature range of 0°C to 70°C
- Single 3.3V power supply
- Maximum link length of 75m/100m/150m on OM3/OM4/OM5 Duplex Multimode Fiber (MMF)
- 4x25Gb/s 850nm VCSEL-based transmitter
- 4x25G CAUI-4 electrical interface
- Duplex LC receptacles
- I2C management interface

APPLICATIONS

- 100G Ethernet over Duplex MMF

Product Selection

FTLC9152RGPL

- R: 100G Ethernet maximum bit rate (103.1Gb/s)
- G: 4x25G coarse SWDM optics
- P: Pull tab release
- L: LC receptacles

I. Pin Descriptions

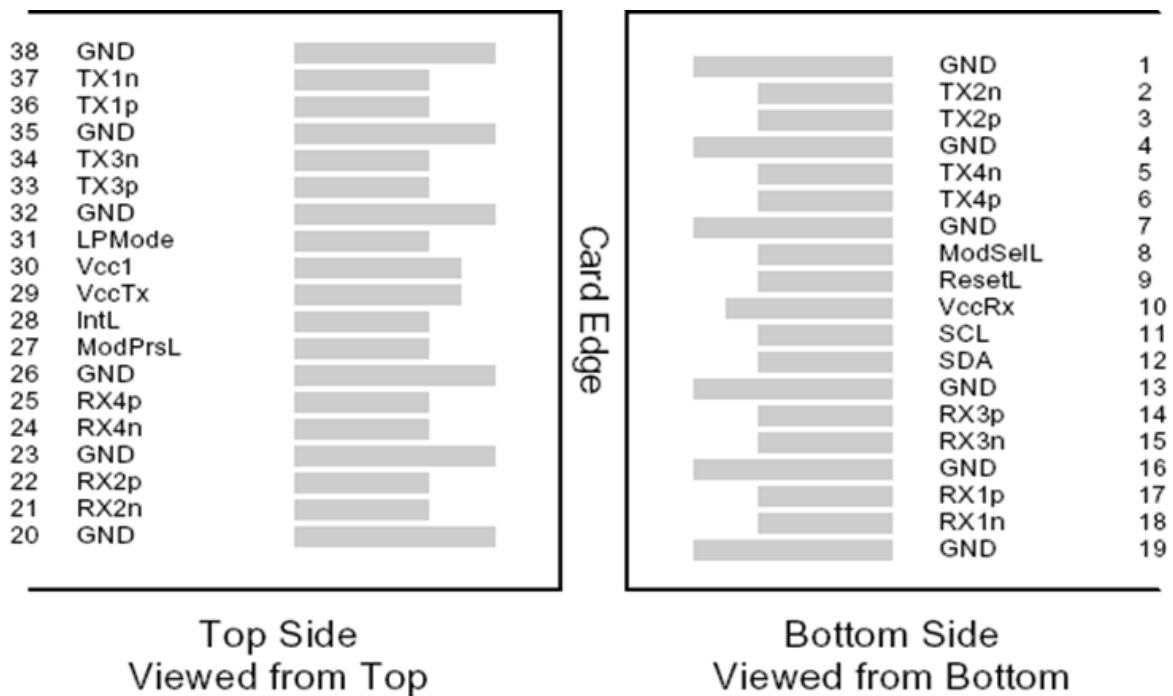

Figure 1 – QSFP28-compliant 38-pin connector (per SFF-8679)

Pin	Symbol	Name/Description	Notes
1	GND	Ground	1
2	Tx2n	Transmitter Inverted Data Input	
3	Tx2p	Transmitter Non-Inverted Data Input	
4	GND	Ground	1
5	Tx4n	Transmitter Inverted Data Input	
6	Tx4p	Transmitter Non-Inverted Data Input	
7	GND	Ground	1
8	ModSelL	Module Select	
9	ResetL	Module Reset	
10	Vcc Rx	+3.3 V Power supply receiver	
11	SCL	2-wire serial interface clock	
12	SDA	2-wire serial interface data	
13	GND	Ground	1
14	Rx3p	Receiver Non-Inverted Data Output	
15	Rx3n	Receiver Inverted Data Output	
16	GND	Ground	1
17	Rx1p	Receiver Non-Inverted Data Output	
18	Rx1n	Receiver Inverted Data Output	
19	GND	Ground	1
20	GND	Ground	1
21	Rx2n	Receiver Inverted Data Output	
22	Rx2p	Receiver Non-Inverted Data Output	
23	GND	Ground	1
24	Rx4n	Receiver Inverted Data Output	
25	Rx4p	Receiver Non-Inverted Data Output	
26	GND	Ground	1
27	ModPrsL	Module Present	
28	IntL	Interrupt	
29	Vcc Tx	+3.3 V Power supply transmitter	
30	Vcc1	+3.3 V Power Supply	
31	LPMode	Low Power Mode	
32	GND	Ground	1
33	Tx3p	Transmitter Non-Inverted Data Input	
34	Tx3n	Transmitter Inverted Data Input	
35	GND	Ground	1
36	Tx1p	Transmitter Non-Inverted Data Input	
37	Tx1n	Transmitter Inverted Data Input	
38	GND	Ground	1

Notes

1. Circuit ground is internally isolated from chassis ground.

II. Absolute Maximum Ratings

Module performance is not guaranteed beyond the operating range (see Section VI). Exceeding the limits below may damage the transceiver module permanently.

Parameter	Symbol	Min	Typ	Max	Unit	Ref.
Maximum Supply Voltage	V _{cc}	-0.5		3.6	V	
Storage Temperature	T _s	-40		85	°C	
Case Operating Temperature	T _{OP}	0		70	°C	1
Relative Humidity	RH	15		85	%	2
Receiver Damage Threshold, per Lane	P _{Rdmg}	3.8			dBm	

Notes:

Non-condensing.

III. Electrical Characteristics (EOL, TOP = -20 to +85 °C, V_{cc} = 3.135 to 3.465 Volts)

Parameter	Symbol	Min	Typ	Max	Unit	Ref.
Supply Voltage	V _{cc}	3.135		3.465	V	
Supply Current	I _{cc}			1.6	A	
Module total power	P			3.5	W	1
Transmitter						
Signaling rate per lane		25.78125 ± 100 ppm			Gb/s	
Differential data input swing per lane	V _{in,pp}			900	mV	
Stressed input parameters						
Single-ended voltage tolerance	V _{in,pp}	-0.35		+3.3	V	
Module stress input test		Per Section 83E.3.4.1, IEEE 802.3bm				
Receiver						
Signaling rate per lane		25.78125 ± 100 ppm			GBd	
Differential data output swing	V _{out,pp}	100		400	mVpp	2
		300		600		
		400	600	800		
		600		1200		
Eye width	EW15	0.57			UI	
Eye height, differential		228			mV	
Vertical eye closure	VEC	5.5			dB	
Transition time (20% to 80%)	t _r , t _f	12			ps	

Notes:

- Maximum total power value is specified across the full temperature and voltage range.
- Output voltage is settable in 4 discrete ranges via I2C. Default range is Range 2 (400 – 800 mV).

IV. Optical Characteristics (EOL, $T_{OP} = 0$ to 70 °C, $V_{CC} = 3.315$ to 3.465 Volts)

Parameter	Symbol	Min	Typ	Max	Unit	Ref.	
Transmitter							
Signaling Speed per Lane		25.78125 ± 100ppm				Gb/s	1
Lane center wavelengths (range)	λ	850	880	910	940	nm	
RMS Spectral Width	SW	0.59	0.59	0.59	0.59	nm	
TxOMA min at max TDEC		-3	-3	-3	-2.9	dBm	
TDEC (OM3)	TDEC	3.3	3.5	3.7	4.2	dB	
TxOMA - TDEC	P-TDEC	-6.3	-6.5	-6.7	-7.1	dBm	
TxOMA min	TxOMA	-5.5	-5.5	-5.5	-5.5	dBm	
Relative Intensity Noise	RIN	-130				dB/Hz	2
Optical Extinction Ratio	ER	2	2	2	2	dB	
Optical Return Loss Tolerance	ORL	12				dB	
Average launch power of OFF transmitter, per lane		-30				dBm	
Transmitter eye mask definition {X1, X2, X3, Y1, Y2, Y3}		{0.3,0.38,0.45,0.35,0.41,0.5}					3
Receiver							
Signaling Speed per Channel		25.78125 ± 100ppm				GBd	4
Lane center wavelengths (range)	λ	850	880	910	940	nm	
Damage Threshold	DT	3.8	3.8	3.8	3.8	dBm	
Average Receive Power per Lane (min)	RXP_{min}	-9.5	-9.4	-9.4	-9.4	dBm	
Average Receive Power per Lane (max)	RXP_{max}	3.4	3.4	3.4	3.4	dBm	
Receiver Reflectance (max)	Rfl	-12				dB	
Stressed Receiver Sensitivity (OMA) per Lane	SRS	-5.2	-5.2	-5.2	-5.2	dBm	5
Back to Back Receiver Sensitivity (OMA) per Lane	RxSens	-8.2	-8.4	-8.6	-8.8	dBm	6
Stressed Conditions:							
Stressed eye closure	SEC	3.3	3.5	3.7	4.2	dB	
Stressed eye J2 jitter	J2	0.39				UI	
Stressed eye J4 jitter	J4	0.53				UI	
Stressed Receiver Eye Mask Definition {X1, X2, X3, Y1, Y2, Y3}		{0.28,0.5,0.5,0.33,0.33,0.4}					
LOS De-Assert (max)	LOS_D	-11				dBm	8
LOS Assert (min)	LOS_A	-30				dBm	8
LOS Hysteresis		0.5				dB	

Notes:

1. Transmitter consists of 4 lasers and a 4:1 optical multiplexer.
2. Informative, link controlled by TDEC
3. Hit Ratio 1.5×10^{-3} hits/sample.
4. Receiver consists of a 1:4 optical de-multiplexer and 4 photodetectors.
5. 5×10^{-5} BER (pre-FEC).
6. Unstressed receiver sensitivity is information, and assumes 5×10^{-5} BER (pre-FEC).
7. Hit Ratio 5×10^{-5} hits/sample.
8. DC values.

V. Link Budget

Parameter	Symbol	Typ	Max	Units	Ref.
Bit Rate (all wavelengths combined)	BR	103.10		Gb/s	
Bit Error Rate	BER		5x10 ⁻⁵		1
Insertion Loss	IL		1.8	dB	2
Maximum Supported Distances					
Fiber Type					
OM3 MMF	Lmax1		75	m	3
OM4 MMF	Lmax2		100	m	3
OM5 MMF	Lmax3		150	m	3

Notes:

1. Tested with a 2³¹ – 1 PRBS at 25.78125 Gb/s
2. 850 nm channel can tolerate 1.9 dB insertion loss
3. Specified at 103.1Gb/s. Requires RS-FEC on the host to support maximum distance.

VI. Environmental Specifications

Finisar FTLC9152 QSFP28 transceivers have a commercial operating case temperature range of 0°C to +70°C. They can support temporary excursions to case temperatures of -5°C and +75°C without permanent damage (see Section II).

Environmental Specifications	Symbol	Min	Typ	Max	Units	Ref.
Case Operating Temperature	Top	0		70	°C	
Storage Temperature	Tsto	-40		85	°C	

VII. Regulatory Compliance

Finisar FTLC9152 QSFP28 transceivers are Class 1 Laser Products. They are certified per the following standards:

Feature	Agency	Standard
Laser Eye Safety	FDA/CDRH	CDRH 21 CFR 1040 and Laser Notice 50
	TÜV	EN 60825-1:2014 EN 60825-2:2004+A1+A2
Electrical Safety	TÜV	EN 60950-1:2006+A11+A1+A12+A2
	UL/CSA	CAN/CSA-C22.2 No. 60950-1-07+A2:2014 ANSI/UL Std. No. 60950-1:2014

Copies of the referenced certificates will be available at Finisar upon request. Complies with FDA performance standards for laser products except for deviations pursuant to Laser Notice No. 50, dated June 24, 2007.

CAUTION – Use of Controls or adjustments or performance of procedures other than those specified herein may result in hazardous radiation exposure.

VIII. Digital Diagnostics Functions

FTLC9152 QSFP28 transceivers support the I2C-based diagnostics interface specified by the QSFP28 MSA¹. See Finisar Application Note AN-2171⁵.

IX. Memory Contents

Per the QSFP28 MSA¹. See Finisar Application Note AN-2171⁵.

XI. Mechanical Specifications

Finisar FTLC9152 QSFP28 transceivers are compatible with the QSFP28 MSA.¹ The pull tab color is grey (Pantone 424U).

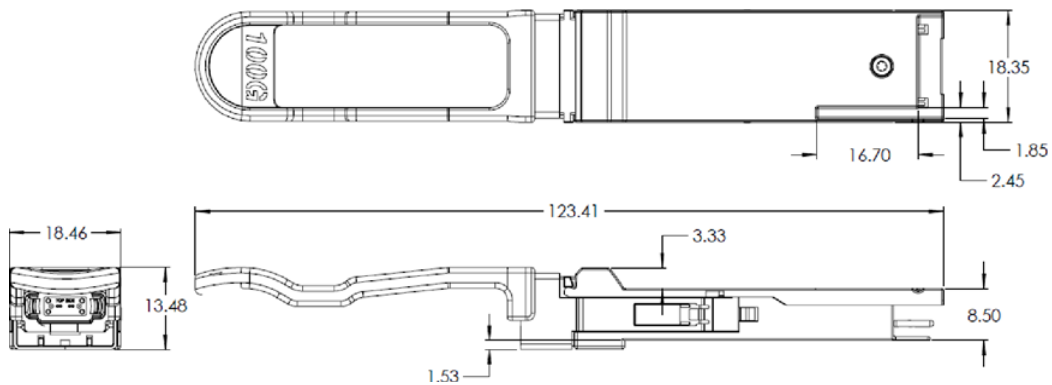

Figure 2. FTLC9152RGPL Mechanical Dimensions.

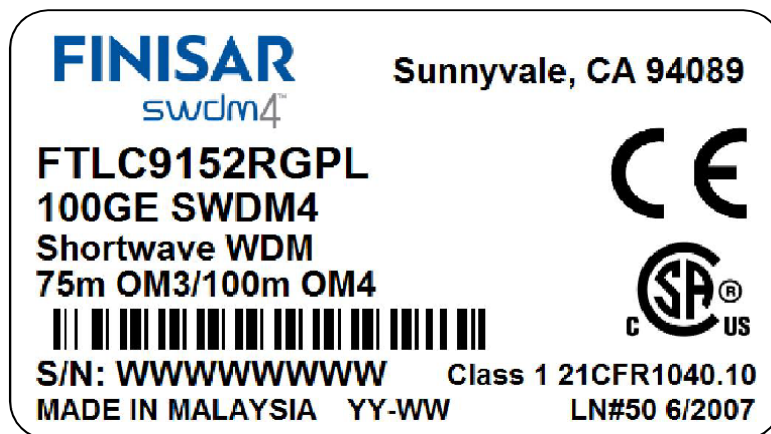

Figure 3. FTLC9152RGPL Product label (not to scale)

X. References

1. SFF-8665: "QSFP+ 28Gb/s 4X Pluggable Transceiver Solution (QSFP28)", Rev 1.9, June 29, 2015 (and associated SFF documents)
 - i. SFF-8661
 - ii. SFF-8679
 - iii. SFF-8636
 - iv. SFF-8662
 - v. SFF-8663
 - vi. SFF-8672
 - vii. SFF-8683
2. IEEE 802.3bm, CAUI-4 interface.
3. Directive 2011/65/EU of the European Parliament and of the Council, "on the restriction of the use of certain hazardous substances in electrical and electronic equipment," July 1, 2011.
4. "Application Note AN-2038: Finisar Implementation Of RoHS Compliant Transceivers", Finisar Corporation, January 21, 2005.
5. Application Note AN-2171, 100G QSFP28 SWDM EEPROM Application Note, Finisar Corporation.