

# FTLC1154SDPL4

## 10km Multi-rate 100G QSFP28 Optical Transceiver Module

FTLC1154SDPL4 QSFP28 transceiver modules are designed for use in 100 Gigabit Ethernet and 4x28G OTN client interface links on up to 10km of single mode fiber. Designed for outside plant applications with an industrial temperature range (-40°C to +85°C), they are compliant with the QSFP28 MSA<sup>1</sup>, IEEE 802.3ba 100GBASE-LR4<sup>2</sup>, IEEE 802.3bm CAUI-4<sup>3</sup> and OTU4 4I1-9D1F requirements specified in ITU-T Recommendations G.959.1/G.709 and Supplement 39 (G.sup39). Digital diagnostic functions are available via the I2C interface, as specified by the QSFP28 MSA and Finisar Application Notes AN-21524 and AN-21535. The optical transceiver is compliant per the RoHS-6 Directive 2011/65/EU<sup>6</sup>. See Finisar Application Note AN-2038<sup>7</sup> for more details.

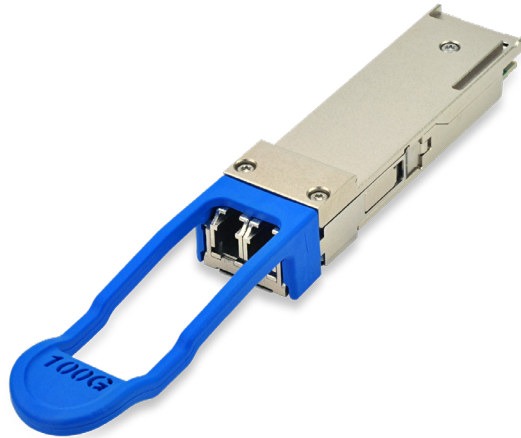

### FEATURES

- Hot-pluggable QSFP28 form factor
- Supports 103.1Gb/s and 112Gb/s aggregate bit rates
- Power dissipation < 4.5W
- RoHS-6 compliant
- Industrial case temperature range of -40°C to 85°C
- Single 3.3V power supply
- Maximum link length of 10km on Single Mode Fiber (SMF)
- 4x28Gb/s DFB-based LAN-WDM transmitter
- 4x28G retimed electrical interface
- Duplex LC receptacles
- I2C management interface

### APPLICATIONS

- OTN OTU4 4I1-9D1F
- 100GBASE-LR4 100G Ethernet
- Outside plant
- Reduced air flow central office

Product Selection

FTLC1154SDPL4

- 4: Gen 2
- S: OTU4 maximum bit rate (112 Gb/s)
- D: 4x28G LAN-WDM optical architecture
- P: Pull-tab release
- L: LC straight receptacles
- 4: Industrial temperature range

1. Pin Descriptions

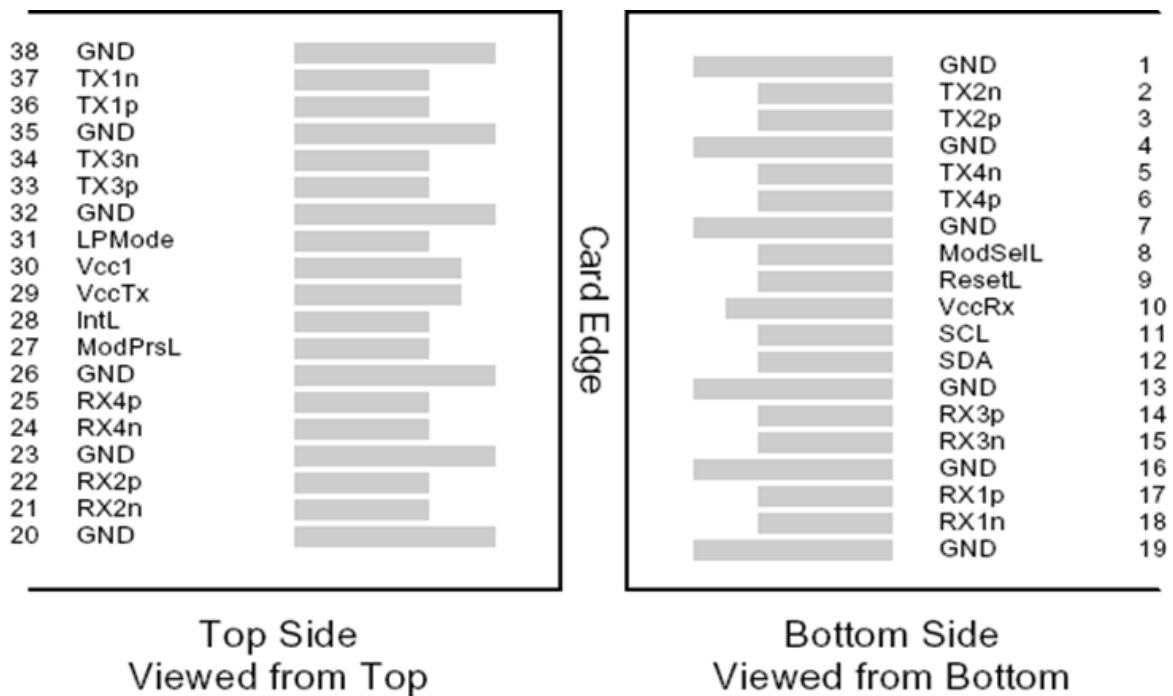

Figure 1 – QSFP28-compliant 38-pin connector (per SFF-8679)

Pin	Symbol	Name/Description	Notes
1	GND	Ground	1
2	Tx2n	Transmitter Inverted Data Input	
3	Tx2p	Transmitter Non-Inverted Data Input	
4	GND	Ground	1
5	Tx4n	Transmitter Inverted Data Input	
6	Tx4p	Transmitter Non-Inverted Data Input	
7	GND	Ground	1
8	ModSelL	Module Select	
9	ResetL	Module Reset	
10	Vcc Rx	+3.3 V Power supply receiver	
11	SCL	2-wire serial interface clock	
12	SDA	2-wire serial interface data	
13	GND	Ground	1
14	Rx3p	Receiver Non-Inverted Data Output	
15	Rx3n	Receiver Inverted Data Output	
16	GND	Ground	1
17	Rx1p	Receiver Non-Inverted Data Output	
18	Rx1n	Receiver Inverted Data Output	
19	GND	Ground	1
20	GND	Ground	1
21	Rx2n	Receiver Inverted Data Output	
22	Rx2p	Receiver Non-Inverted Data Output	
23	GND	Ground	1
24	Rx4n	Receiver Inverted Data Output	
25	Rx4p	Receiver Non-Inverted Data Output	
26	GND	Ground	1
27	ModPrsL	Module Present	
28	IntL	Interrupt	2
29	Vcc Tx	+3.3 V Power supply transmitter	
30	Vcc1	+3.3 V Power Supply	
31	LPMode	Low Power Mode	2
32	GND	Ground	1
33	Tx3p	Transmitter Non-Inverted Data Input	
34	Tx3n	Transmitter Inverted Data Input	
35	GND	Ground	1
36	Tx1p	Transmitter Non-Inverted Data Input	
37	Tx1n	Transmitter Inverted Data Input	
38	GND	Ground	1

## Notes

1. Circuit ground is internally isolated from chassis ground.
2. The IntL pin ("Interrupt Low", pin 28) can be configured to act as an Rx\_LOS output; The LPMode pin ("Low Power Mode", pin 31) can be configured to act as an input for Tx\_Disable; These changes require customization. See Finisar Application Note AN-2174<sup>3</sup> for more details.

## II. Absolute Maximum Ratings

Module performance is not guaranteed beyond the operating range (see Section VI). Exceeding the limits below may damage the transceiver module permanently.

Parameter	Symbol	Min	Typ	Max	Unit	Ref.
Maximum Supply Voltage	V <sub>CC</sub>	-0.5		3.6	V	
Storage Temperature	T <sub>S</sub>	-40		+85	°C	
Case Operating Temperature	T <sub>OP</sub>	-40		+85	°C	
Relative Humidity	RH	15		85	%	1
Receiver Damage Threshold, per Lane	P <sub>Rdmg</sub>	5.5			dBm	

Notes:

1. Non-condensing.

**III. Electrical Characteristics (EOL, TOP = -40 to 85 °C, V<sub>cc</sub> = 3.135 to 3.465 Volts)**

Parameter	Symbol	Min	Typ	Max	Unit	Ref.
Supply Voltage	V <sub>cc</sub>	3.135		3.465	V	
Supply Current	I <sub>cc</sub>			1.6	A	
Module total power	P			4.5	W	1
<b>Transmitter</b>						
Signaling rate per lane		25.78		27.95	Gb/s	
Differential data input swing per lane	V <sub>in,pp</sub>			900	mV	
Differential input return loss (min) at LR4	RL <sub>d</sub> (f)	$9.5 - 0.37f, 0.01 \leq f < 8$ $4.75 - 7.4 \log_{10}(f/14), 8 \leq f < 19$			dB	
Differential to common mode input return loss (min) at LR4	RL <sub>dc</sub> (f)	$22 - 20(f/25.78), 0.01 \leq f < 12.89$ $15 - 6(f/25.78), 12.89 \leq f < 19$			dB	
Differential input return loss (min) at OTU4	SDD11	$-11, 0.05 < f < f_b$ $-6.0 + 9.2 \log_{10}(2f/f_b), f_b/7 < f < f_b$			dB	2
Differential to common mode input return loss (min) at OTU4	SDC11 SCD11	$-22 + 14(f/f_b), 0.05 < f < f_b/2$ $-18 + 6f/f_b, f_b/2 < f < f_b$			dB	2
Differential termination mismatch				10	%	
Stressed input parameters						
Eye width			0.46		UI	
Applied pk-pk sinusoidal jitter		Per IEEE 802.3bm Table 88-13				
Eye height			95		mV	
DC common mode voltage		-350		2850	mV	

Receiver						
Signaling rate per lane		25.78125		27.9525	GBd	
Differential data output swing	Vout,pp	100		400	mVpp	2
		300		600		
		400		800		
		600		1200		
Eye width	EW15	0.57			UI	4
Eye height	EH15	228			mV	4
Vertical eye closure				5.5	dB	
Differential output return loss (min) at LR4	RLd(f)	$9.5 - 0.37f, 0.01 \leq f < 8$ $4.75 - 7.4 \log_{10}(f/14), 8 \leq f < 19$			dB	
Common to differential mode conversion return loss (min) at LR4	RLdc(f)	$22 - 20(f/25.78), 0.01 \leq f < 12.89$ $15 - 6(f/25.78), 12.89 \leq f < 19$			dB	
Differential output return loss (min) at OTU4	SDD22	$-11, 0.05 < f < fb$ $-6.0 + 9.2 \log_{10}(2f/fb), fb/7 < f < fb$			dB	2
Common to differential mode conversion return loss (min) at OTU4	SDC22	$-25 + 20(f/fb), 0.05 < f < fb/2$			dB	2
	SCD22	$-18 + 6f/fb, fb/2 < f < fb$				
Common mode return loss at OTU4	SCC22			-2	dB	5
Common mode noise, RMS				17.5	mV	
Differential termination mismatch				10	%	
Transition time, 20% to 80% at LR4	$t_r, t_f$	12			ps	
Transition time, 20% to 80% at OTU4	$t_r, t_f$	9.5			ps	

## Notes:

1. Maximum total power value is specified across the full temperature and voltage range. Power consumption  $\leq 4.5W$  when stabilized (both Tx and Rx CDR locked), but may be  $\leq 5W$  during locking acquisition.
2. fb is the data rate per lane in Gb/s
3. Output voltage is settable in 4 discrete ranges via I2C. Default range is 400 – 800 mV.
4. Defined at  $10^{-15}$  probability.
5. From 250 MHz to 30 GHz.

**IV. Optical Characteristics (EOL,  $T_{OP} = -40$  to  $85$  °C,  $V_{CC} = 3.135$  to  $3.465$  Volts)**
**OTU4 4I1-9D1F Operation**

Parameter	Symbol	Min	Typ	Max	Unit	Ref.
Transmitter						
Signaling Speed per Channel			27.9525± 20 ppm		Gb/s	1
Channel center wavelengths (range)			1294.53 – 1296.59 1299.02 – 1301.09 1303.54 – 1305.63 1308.09 – 1310.19		nm	
Total Average Launch Power	$P_{OUT}$			10	dBm	
Average Launch Power per Channel	$TXP_x$	-0.6		4.0	dBm	5
Optical Channel Extinction Ratio	ER	4.0		6.5	dB	
Channel Power Difference	$\Delta P_{OUT}$			5	dB	
Optical Return Loss	ORL			20	dB	
Transmitter eye mask definition {X1, X2, X3, Y1, Y2, Y3}			{0.25, 0.4, 0.45, 0.25, 0.28, 0.4}			3
Receiver						
Signaling Speed per Lane			27.9525± 20 ppm		GBd	3
Lane center wavelengths (range)			1294.53 – 1296.59 1299.02 – 1301.09 1303.54 – 1305.63 1308.09 – 1310.19		nm	
Average Input Power per Channel	$RXP_x$	-6.9		4.0	dBm	4,5
Optical Path Penalty	OPP			1.5	dB	
Equivalent Sensitivity per Channel	Rxsens			-8.4	dBm	4
Total Average Input Power	PIN			10.0	dBm	
Channel Power Difference	$\Delta PIN$			5.5	dB	
LOS De-Assert	$LOS_D$			-11.6	dBm	
LOS Assert	$LOS_A$	-24		-13.6	dBm	
LOS Hysteresis			1.5		dBm	

## Notes:

1. Transmitter consists of 4 lasers operating at 27.95Gb/s each.
2. Hit ratio  $5 \times 10^{-5}$ .
3. Receiver consists of 4 photodetectors operating at 27.95Gb/s each.
4. Specified at a BER of  $10^{-6}$  (pre-FEC), per ITU-T G.sup39.
5. Power value and power accuracy are with all channels on.

## 100GBASE-LR4 Operation

Parameter	Symbol	Min	Typ	Max	Unit	Ref.
Transmitter						
Signaling Speed per Channel			25.78125 ± 100 ppm		Gb/s	1
Channel center wavelengths (range)			1294.53 – 1296.59 1299.02 – 1301.09 1303.54 – 1305.63 1308.09 – 1310.19		nm	
Total Average Launch Power	POUT			10.5	dBm	
Transmit OMA per Lane	TxOMA	-1.3		4.5	dBm	
Average Launch Power per Lane	TXPx	-4.3		4.5	dBm	2,7
Optical Extinction Ratio	ER	4			dB	
Sidemode Suppression ratio	SSRmin	30			dB	
Average launch power of OFF transmitter, per lane				-30	dBm	
Relative Intensity Noise	RIN			-130	dB/Hz	
Optical Return Loss Tolerance				20	dB	
Transmitter Reflectance				-12	dB	
Transmitter eye mask definition {X1, X2, X3, Y1, Y2, Y3}			{0.25, 0.4, 0.45, 0.25, 0.28, 0.4}			3
Receiver						
Signaling Speed per Lane			25.78125 ± 100 ppm		GBd	3
Lane center wavelengths (range)			1294.53 – 1296.59 1299.02 – 1301.09 1303.54 – 1305.63 1308.09 – 1310.19		nm	
Receive Power (OMA) per Lane	RxOMA			4.5	dBm	
Average Receive Power per Lane	RXPx	-10.6		4.5	dBm	5,7
Receiver Sensitivity (OMA) per Lane	Rxsens			-8.6	dBm	
Return Loss	RL	-26			dB	
Stressed Receiver Sensitivity (OMA) per Lane	SRS			-6.8	dBm	6
Receive electrical 3 dB upper cutoff frequency, per lane				31	GHz	
LOS De-Assert	LOSD			-11.6	dBm	
LOS Assert	LOSA	-24		-13.6	dBm	
LOS Hysteresis			1.5		dBm	

## Notes:

1. Transmitter consists of 4 lasers operating at 25.78Gb/s each. Power consumption < 3.5W when stabilized, but may be > 3.5W during acquisition.
2. Minimum value is informative.
3. Hit ratio 5x10<sup>-5</sup>.
4. Receiver consists of 4 photodetectors operating at 25.78Gb/s each.
5. Minimum value is informative, equals min TxOMA with infinite ER and max channel insertion loss.
6. SRS is measured with vertical eye closure penalty of 1.8 dB max, J2 of 0.30 UI, and J9 of 0.47 UI.
7. Power value and power accuracy are with all channels on.



## V. General Specifications

Parameter	Symbol	Typ	Max	Units	Ref.	
Bit Rate (all wavelengths combined)	BR	103.1		112.0	Gb/s	1
Bit Error Ratio @25.78Gb/s	BER1			10 <sup>-12</sup>		2
Bit Error Ratio @27.95Gb/s	BER2			10 <sup>-6</sup>		3
Maximum Supported Distances						
Fiber Type						
SMF per G.652	Lmax			10	km	

### Notes:

1. Supports OTU4 4I1-9D1F per ITU-T G.959.1 and 100GBASE-LR4 per IEEE 802.3ba.
2. Tested with a 2<sup>31</sup> - 1 PRBS.
3. Tested with a 2<sup>31</sup> - 1 PRBS. Per ITU-T G.959.1 and G.sup39, the BER of 10-12 for the OTU4 (112 Gb/s) application code is required to be met only after forward error correction has been applied. ITU-T G.sup39 defines the pre-FEC BER to be met as 10-6. The values for receiver sensitivity and optical path penalty measured at the receiver output at a BER of 10-6 will normally be conservative estimates of the values for receiver sensitivity and path penalty at the BER of 10-12 after the FEC decoder.

## VI. Environmental Specifications

Finisar FTLC1154SDPL4 QSFP28 transceivers have an operating case temperature range of -40°C to +85°C.

Environmental Specifications	Symbol	Min	Typ	Max	Units	Ref.
Case Operating Temperature	Top	-40		+85	°C	
Storage Temperature	Tsto	-40		+85	°C	

## VII. Regulatory Compliance

Finisar FTLC1154SDPL4 QSFP28 transceivers are Class 1 Laser Products. They are certified per the following standards:

Feature	Agency	Standard
Laser Eye Safety	FDA/CDRH	CDRH 21 CFR 1040 and Laser Notice 50
	CSA	IEC60825-2:2004+A1+A2
	TÜV	EN 60825-1:2014 EN 60825-2:2004+A1+A2
Electrical Safety	CSA	IEC60950-1:2005+A1+A2
	TÜV	EN 60950-1:2006+A11+A1+A12+A2
	UL/CSA	CAN/CSA-C22.2 No. 60950-1-07+A2:2014 ANSI/UL Std. No. 60950-1:2014

Copies of the referenced certificates are available at Finisar Corporation upon request.

## VIII. Digital Diagnostics Functions

FTLC1154SDPL4 QSFP28 transceivers support the I2C-based diagnostics interface specified by the SFF Committee<sup>1</sup>. See also Finisar Application Notes AN-2152<sup>4</sup> and AN- 2153<sup>5</sup>.

**IX. Memory Contents**

Per SFF-8665 Specification<sup>1</sup>. See Finisar Application Note AN-2152<sup>4</sup>. For CFP replacement applications, the transceiver module can be customized to enable Tx\_Disable and Rx\_LOS functions as alternate functions on LPMODE and IntL pins. See Finisar Application Note AN-2174<sup>8</sup> for more details.

**XI. Mechanical Specifications**

Finisar FTLC1154SDPL4 transceivers are compatible with the QSFP28 Specification for pluggable form factor modules.

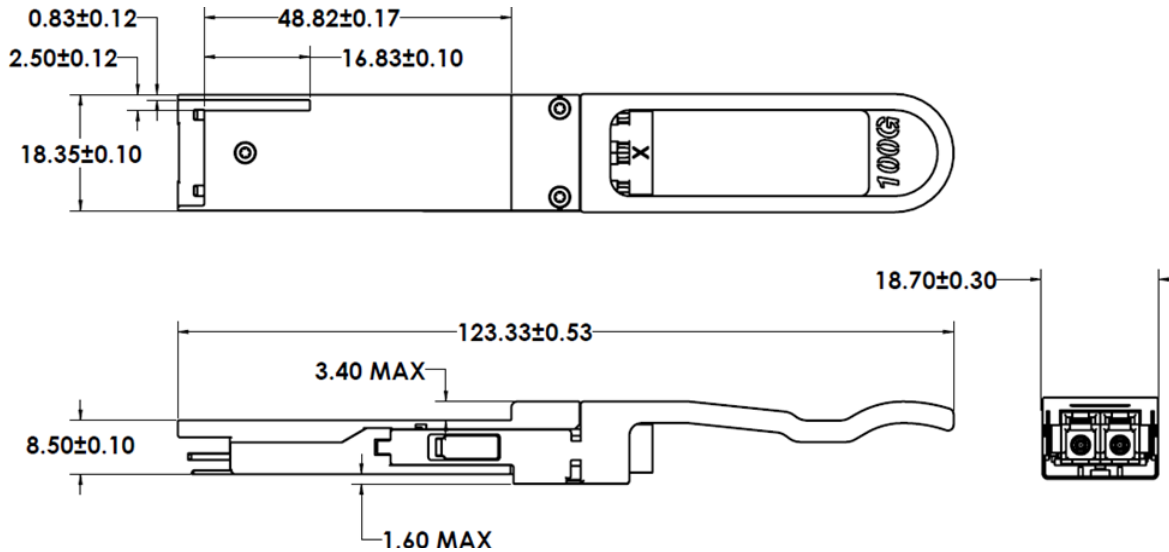

Figure 2. FTLC1154SDPL4 Mechanical Dimensions.

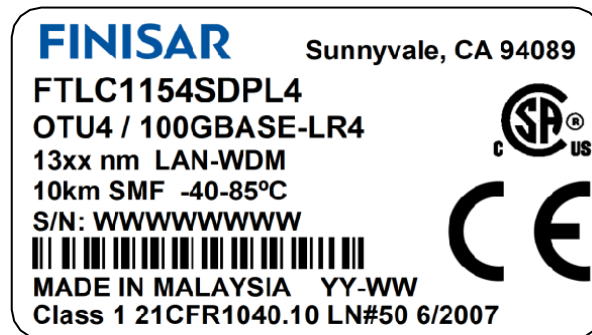

Figure 3. Product Label (Not to Scale)

**X. References**

1. SFF-8665: "QSFP+ 28Gb/s 4X Pluggable Transceiver Solution (QSFP28)", Rev 1.9, June 29, 2015 (and associated SFF documents)
  - i. SFF-8661
  - ii. SFF-8679
  - iii. SFF-8636
  - iv. SFF-8662
  - v. SFF-8663
  - vi. SFF-8672
  - vii. SFF-8683
2. IEEE 802.3ba, PMD Type 100GBASE-LR4.
3. IEEE 802.3bm, Annex 83E, CAUI-4 Interface.
4. Application Note AN-2152: EEPROM Map, Finisar Corporation.
5. Application Note AN-2153: Initialization, Finisar Corporation.
6. Directive 2011/65/EU of the European Parliament and of the Council, "on the restriction of the use of certain hazardous substances in electrical and electronic equipment," July 1, 2011.
7. Application Note AN-2038: Finisar Implementation Of RoHS Compliant Transceivers, Finisar Corporation.
8. Application Note AN-2174: QSFP28 LR4 and QSFP28 CWDM4 – Tx\_Disable and Rx\_LOS Capability, Finisar Corporation.