

FTL4C1QL2L

40GBASE-LR4 Lite QSFP+ Optical Transceiver Module

FTL4C1QL2L QSFP+ transceiver modules are designed for use in 40 Gigabit Ethernet links over single mode fiber. They are compliant with the QSFP+ MSA^{1,2} and are compatible with IEEE 802.3ba 40GBASE-LR4³ up to 2 km. Digital diagnostics functions are available via an I2C interface, as specified by the QSFP+ MSA. The optical transceiver is compliant per the RoHS Directive 2011/65/EU⁴. See Finisar Application Note AN-2038 for more details⁵.

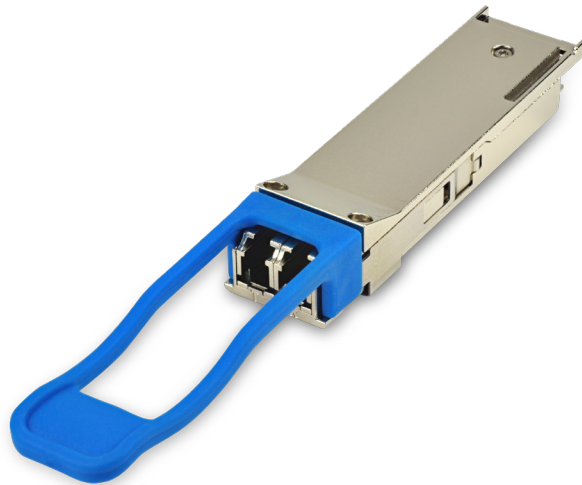

FEATURES

- Hot-pluggable QSFP+ form factor
- Supports 41.2 Gb/s aggregate bit rates
- Power dissipation < 2.5W
- RoHS-6 compliant
- Lite case temperature range 15°C to 60°C
- Single 3.3V power supply
- Maximum link length of 2km on Single Mode Fiber (SMF)
- Uncooled 4x10Gb/s CWDM transmitter
- XLPP1 electrical interface
- Duplex LC receptacles
- Built-in digital diagnostic functions, including Tx/Rx power monitoring¹

APPLICATIONS

- 40GBASE-LR4 Lite 40G Ethernet

Product Selection

FTL4C1QL2L

- FTL: Finisar transceiver
- L: Lite (non-standard) optical interface
- 4: 4 channel module
- 2: Second generation product
- C1: 13xx nm CWDM on SMF
- L: Lite temperature range
- Q: QSFP+ form factor

I. Pin Descriptions

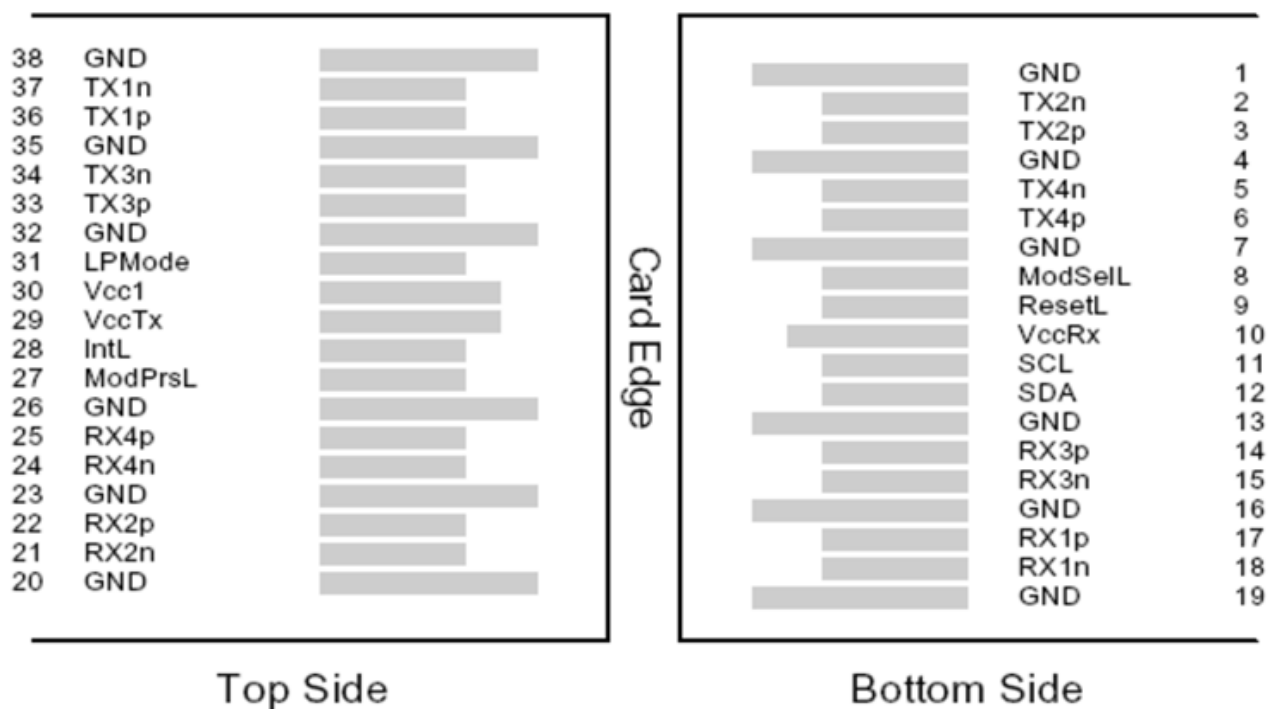

Figure 1 – QSFP+ MSA-compliant 38-pin connector

Pin	Symbol	Name/Description	Notes
1	GND	Ground	1
2	Tx2n	Transmitter Inverted Data Input	
3	Tx2p	Transmitter Non-Inverted Data Input	
4	GND	Ground	1
5	Tx4n	Transmitter Inverted Data Input	
6	Tx4p	Transmitter Non-Inverted Data Input	
7	GND	Ground	1
8	ModSelL	Module Select	
9	ResetL	Module Reset	
10	Vcc Rx	+3.3 V Power supply receiver	
11	SCL	2-wire serial interface clock	
12	SDA	2-wire serial interface data	
13	GND	Ground	1
14	Rx3p	Receiver Non-Inverted Data Output	
15	Rx3n	Receiver Inverted Data Output	
16	GND	Ground	1
17	Rx1p	Receiver Non-Inverted Data Output	
18	Rx1n	Receiver Inverted Data Output	
19	GND	Ground	1
20	GND	Ground	1
21	Rx2n	Receiver Inverted Data Output	
22	Rx2p	Receiver Non-Inverted Data Output	
23	GND	Ground	1
24	Rx4n	Receiver Inverted Data Output	
25	Rx4p	Receiver Non-Inverted Data Output	
26	GND	Ground	1
27	ModPrsL	Module Present	
28	IntL	Interrupt	
29	Vcc Tx	+3.3 V Power supply transmitter	
30	Vcc1	+3.3 V Power Supply	
31	LPMODE	Low Power Mode	
32	GND	Ground	1
33	Tx3p	Transmitter Non-Inverted Data Input	
34	Tx3n	Transmitter Inverted Data Input	
35	GND	Ground	1
36	Tx1p	Transmitter Non-Inverted Data Input	
37	Tx1n	Transmitter Inverted Data Input	
38	GND	Ground	1

Notes

1. Circuit ground is internally isolated from chassis ground.

II. General Product Characteristics

Parameter	Value	Unit	Notes
Module Form Factor	QSFP+		
Maximum Aggregate Data Rate	41.2	Gb/s	
Maximum Data Rate per Lane	10.3	Gb/s	
Protocols Supported	40G Ethernet		
Electrical Interface and Pin-out	38-pin edge connector		Pin-out as defined by the QSFP+ MSA
Management Interface	2.5	Watts	
Management Interface	Serial, I2C-based, 400 kHz maximum frequency		As defined by the QSFP+ MSA

Data Rate Specifications	Symbol	Min	Typ	Max	Units	Ref.
Bit Rate per Lane	BR			10.313	Mb/sec	1
Bit Error Ratio	BER			10^{-12}		2
Link distance on SMF-28	d			2	km	3

Notes:

- Compliant with 40GBASE-LR4 and XLPP1 per IEEE 802.3ba. Compatible with 1/10 Gigabit Ethernet and 1/2/4/8/10G Fibre Channel.
- Tested with a PRBS 2³¹-1 test pattern.

III. Absolute Maximum Ratings

Parameter	Symbol	Min	Typ	Max	Unit	Ref.
Maximum Supply Voltage	V _{cc1} , V _{ccTx} , V _{ccRx}	-0.5		3.6	V	
Storage Temperature	T _s	-40		85	°C	
Case Operating Temperature	T _{OP}	15		60	°C	
Relative Humidity	RH	0		85	%	1
Damage Threshold, per Lane	DT	3.4			dBm	

Notes:

Non-condensing.

IV. Electrical Characteristics ($T_{op} = 15$ to 60°C , $V_{cc} = 3.1$ to 3.47 Volts)

Parameter	Symbol	Min	Typ	Max	Unit	Ref.
Supply Voltage	Vcc1, VccTx, VccRx	3.1		3.47	V	
Supply Current	Icc			1.13	A	
Link turn-on time						
Transmit turn-on time				2000	ms	2
Transmitter (per Lane)						
Single ended input voltage tolerance	VinT	-0.3		4.0	V	
Differential data input swing	Vin,pp	120		1200	mVpp	3
Differential input threshold			50		mV	
AC common mode input voltage tolerance (RMS)		15			mV	
Differential input return loss		Per IEEE P802.3ba, Section 86A.4.1.1			dB	4
J2 Jitter Tolerance	Jt2	0.17			UI	
J9 Jitter Tolerance	Jt9	0.29			UI	
Data Dependent Pulse Width Shrinkage	DDPWS	0.07			UI	
Eye mask coordinates {X1, X2 Y1, Y2}		0.11, 0.31 95, 350			UI mV	5
Receiver (per Lane)						
Single-ended output voltage		-0.3		4.0	V	
Differential data output swing	Vout,pp	200		400	mVpp	6, 7
		300		600		
		400	550	800		
		600		1200		
AC common mode output voltage (RMS)				7.5	mV	
Termination mismatch at 1 MHz				5	%	
Differential output return loss		Per IEEE P802.3ba, Section 86A.4.2.1			dB	4
Common mode output return loss		Per IEEE P802.3ba, Section 86A.4.2.2			dB	4
Output transition time, 20% to 80%		28			ps	
J2 Jitter output	Jo2			0.42	UI	
J9 Jitter output	Jo9			0.65	UI	
Eye mask coordinates #1 {X1, X2 Y1, Y2}		0.29, 0.5 150, 425			UI mV	5
Power Supply Ripple Tolerance	PSR	50			mVpp	

Notes:

1. Maximum total power value is specified across the full temperature and voltage range.
2. From power-on and end of any fault conditions.
3. After internal AC coupling. Self-biasing 100Ω differential input.
4. 10 MHz to 11.1 GHz range.
5. Hit ratio = 5×10^{-5} .
6. AC coupled with 100Ω differential output impedance.
7. Output voltage is settable in 4 discrete steps via I2C. Default is 400 – 800 mV.

V. Optical Characteristics ($T_{OP} = 15$ to 60°C , $V_{CC} = 3.1$ to 3.47 Volts)

Parameter	Symbol	Min	Typ	Max	Unit	Ref.
Transmitter						
Signaling Speed per Lane			10.3125		GBd	1
Lane center wavelengths (range)			1264.5 – 1277.5 1284.5 – 1297.5 1304.5 – 1317.5 1324.5 – 1337.5		nm	
Total Average Launch Power	P_{OUT}			8.3	dBm	
Transmit OMA per Lane	TxOMA	-6.0		3.5	dBm	
Average Launch Power per Lane	TXPx	-10.0		2.3	dBm	2
Optical Extinction Ratio	ER	3.5			dB	
Transmitter and Dispersion Penalty	TDP			2.3	dB	
Transmit OMA minus TDP, per lane	Tx-TDP	-7.8			dBm	
Sidemode Suppression ratio	SSR_{min}	30			dB	
Average launch power of OFF transmitter, per lane				-30	dBm	
Relative Intensity Noise	RIN			-128	dB/Hz	3
Optical Return Loss Tolerance				20	dB	
Transmitter Reflectance				-12	dB	
Transmitter eye mask definition {X1, X2, X3, Y1, Y2, Y3}			{0.25, 0.4, 0.45, 0.25, 0.28, 0.4}			

Parameter	Symbol	Min	Typ	Max	Unit	Ref.
Receiver per Lane						
Signaling Speed per Lane		10.3125		10.3125	GBd	4
Lane center wavelengths (range)			1264.5 – 1277.5 1284.5 – 1297.5 1304.5 – 1317.5 1324.5 – 1337.5		nm	
Receive Power (OMA) per Lane	RxOMA			3.5	dBm	
Average Receive Power per Lane	RXPx	-13.7		2.3	dBm	5
Receiver Sensitivity (OMA) per Lane	Rxsens			-10.5	dBm	6
Stressed Receiver Sensitivity (OMA) per Lane	SRS			-8.5	dBm	
Damage Threshold per Lane	PMAX			3.3	dBm	
Return Loss	RL			-26	dB	
Vertical eye closure penalty, per lane				1.9	dB	
Receive electrical 3 dB upper cutoff frequency, per lane				12.3	GHz	
LOS De-Assert	LOS _D			-15	dBm	
LOS Assert	LOS _A	-28			dBm	
LOS Hysteresis		0.5			dBm	

Notes:

1. Transmitter consists of 4 lasers operating at 10.3Gb/s each.
2. Minimum value is informative.
3. RIN is scaled by $10 \cdot \log(10/4)$ to maintain SNR outside of transmitter.
4. Receiver consists of 4 photodetectors operating at 10.3Gb/s each.
5. Minimum value is informative, equals min TxOMA with infinite ER and max channel insertion loss.
6. Rx sensitivity is at BER 10^{-12} .

VI. Memory Map and Control Registers

Compatible with SFF-8636 Rev 2.7 (QSFP+). Please see Finisar Application Note AN- 2104⁶ for a complete EEPROM map.

VII. Environmental Specifications

Finisar FTL4C1QL2L transceivers have an operating temperature range from 15°C to +60°C case temperature.

Environmental Specifications	Symbol	Min	Typ	Max	Units	Ref.
Case Operating Temperature	Top	15		60	°C	
Storage Temperature	Tsto	-40		85	°C	

VIII. Regulatory Compliance

Finisar FTL4C1QL2L transceivers are RoHS-6 Compliant. Copies of certificates are available at Finisar Corporation upon request.

FTL4C1QL2C transceiver modules are Class 1 laser eye safety compliant per IEC 60825-1.

IX. Mechanical Specifications

The FTL4C1QL2L mechanical specifications are compliant to the QSFP+ MSA transceiver module specifications.

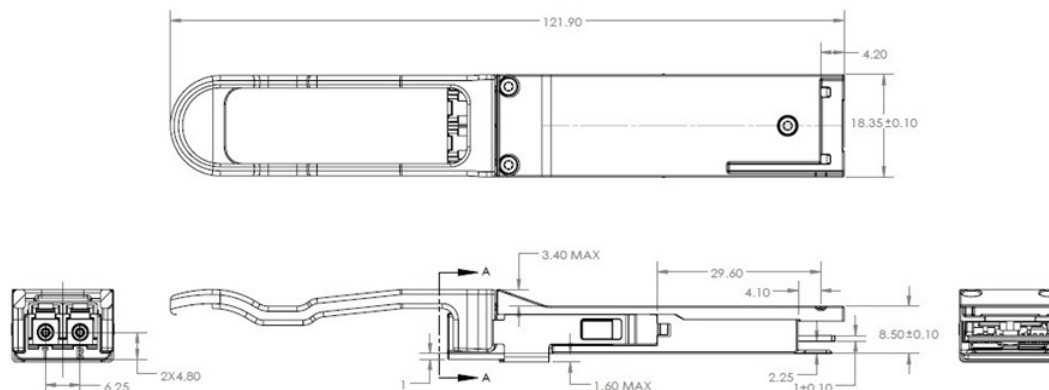

Figure 2 – FTL4C1QL2L mechanical drawing



Figure 3 – FTL4C1QL2L label (not to scale)

X. References

1. INF-8438i – Specification for QSFP (Quad Small Formfactor Pluggable) Transceiver, Rev 1.0, November 2006, superseded by SFF-8636 Rev 2.7.
2. SFF-8636 – Specification for QSFP+ Copper and Optical Transceiver, Rev 2.7
3. IEEE 802.3ba – PMD Type 40GBASE-LR4.
4. Directive 2011/65/EU of the European Council Parliament and of the Council, “on the restriction of the use of certain hazardous substances in electrical and electronic equipment”. Certain products may use one or more exemptions as allowed by the Directive.
5. “Application Note AN-2038: Finisar Implementation of RoHS Compliant Transceivers”.
6. “Application Note AN-2104: QSFP+ 40G LR4 Transceiver EEPROM Mapping,” Rev. A, Finisar Corporation, June, 2013.