

# FTL410QE3C

## 40BASE-SR4 QSFP+ Gen3 Optical Transceiver Module

FTL410QE3C QSFP+ transceiver modules are designed for use in 40 Gigabit per second links over multimode fiber. They are compliant with the QSFP+ MSA<sup>1,2</sup> and IEEE 802.3ba 40GBASE-SR4<sup>3</sup> and breakout to 4 10GBASE-SR. Digital diagnostics functions are available via an I2C interface, including Tx and Rx power monitoring. The optical transceiver is compliant per the RoHS Directive 2011/65/EU<sup>4</sup>. See Finisar Application Note AN-2038 for more details<sup>5</sup>.



### FEATURES

- Four-channel full-duplex transceiver module
- Hot Pluggable QSFP+ form factor
- Maximum link length of 100m on OM3 Multimode Fiber (MMF) and 150m on OM4 MMF
- Multirate capability: 1.06Gb/s to 10.5Gb/s per channel
- Unretimed XLPP electrical interface
- Max power dissipation <1.2W
- Reliable VCSEL array technology
- Built-in digital diagnostic functions, including optical power monitoring
- Commercial operating case temperature range: 0°C to 70°C
- Single 1x12 MPO receptacle
- RoHS-6 Compliant

### APPLICATIONS

- 40GBASE-SR4 40G Ethernet
- Breakout to 4 x 10GBASE-SR Ethernet
- Proprietary interconnections

Product Selection

FTL410QE3C

I. Pin Descriptions

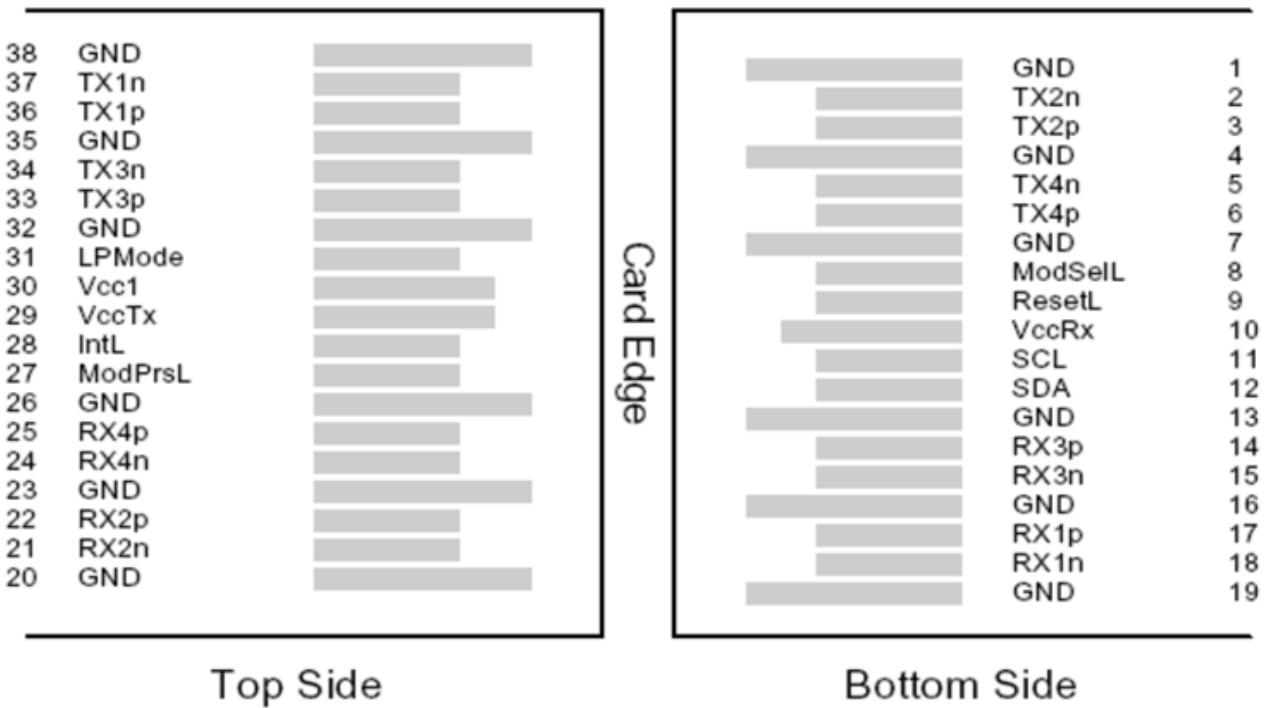

Figure 1 – QSFP+ MSA-compliant 38-pin connector

Pin	Symbol	Name/Description	Notes
1	GND	Ground	1
2	Tx2n	Transmitter Inverted Data Input	
3	Tx2p	Transmitter Non-Inverted Data Input	
4	GND	Ground	1
5	Tx4n	Transmitter Inverted Data Input	
6	Tx4p	Transmitter Non-Inverted Data Input	
7	GND	Ground	1
8	ModSelL	Module Select	
9	ResetL	Module Reset	
10	Vcc Rx	+3.3 V Power supply receiver	
11	SCL	2-wire serial interface clock	
12	SDA	2-wire serial interface data	
13	GND	Ground	1
14	Rx3p	Receiver Non-Inverted Data Output	
15	Rx3n	Receiver Inverted Data Output	
16	GND	Ground	1
17	Rx1p	Receiver Non-Inverted Data Output	
18	Rx1n	Receiver Inverted Data Output	
19	GND	Ground	1
20	GND	Ground	1
21	Rx2n	Receiver Inverted Data Output	
22	Rx2p	Receiver Non-Inverted Data Output	
23	GND	Ground	1
24	Rx4n	Receiver Inverted Data Output	
25	Rx4p	Receiver Non-Inverted Data Output	
26	GND	Ground	1
27	ModPrsL	Module Present	
28	IntL	Interrupt	
29	Vcc Tx	+3.3 V Power supply transmitter	
30	Vcc1	+3.3 V Power Supply	
31	LPMODE	Low Power Mode	
32	GND	Ground	1
33	Tx3p	Transmitter Non-Inverted Data Input	
34	Tx3n	Transmitter Inverted Data Input	
35	GND	Ground	1
36	Tx1p	Transmitter Non-Inverted Data Input	
37	Tx1n	Transmitter Inverted Data Input	
38	GND	Ground	1

## Notes

1. Circuit ground is internally isolated from chassis ground.

## II. General Product Characteristics

Parameter	Value	Unit	Notes
Module Form Factor	QSFP+		
Number of Lanes	4 Tx and 4 Rx		
Maximum Aggregate Data Rate	42.0	Gb/s	
Maximum Data Rate per Lane	10.5	Gb/s	Higher bit rates may be supported. Please contact Finisar.
Protocols Supported	Typical applications include 40G Ethernet, Infiniband QDR, SATA/SAS3		This module is not retimed
Electrical Interface and Pin-out	38-pin edge connector		Pin-out as defined by the QSFP+ MSA <sup>2</sup>
Maximum Power Consumption per End	1.2	Watts	Varies with output voltage swing and pre-emphasis settings
Management Interface	Serial, I2C-based, 400 kHz maximum frequency		As defined by the QSFP+ MSA <sup>2</sup>

Data Rate Specifications	Symbol	Min	Typ	Max	Units	Ref.
Bit Rate per Lane	BR	1062		10500	Mb/sec	1
Bit Error Ratio	BER			10 <sup>-12</sup>		2
Link distance on OM3 MMF	d			100	meters	3
Link distance on OM4 MMF	d			150	meters	3

### Notes:

1. Compliant with 40G Ethernet. Compatible with 1/10 Gigabit Ethernet and 1/2/4/8/10G Fibre Channel.
2. Tested with a PRBS 231-1 test pattern.
3. Per 40GBASE-SR4, IEEE 802.3ba

## III. Absolute Maximum Ratings

Parameter	Symbol	Min	Typ	Max	Unit	Ref.
Maximum Supply Voltage	V <sub>CC1</sub> , V <sub>CC</sub> Tx, V <sub>CC</sub> Rx	-0.5		3.6	V	
Storage Temperature	T <sub>S</sub>	-40		85	°C	
Case Operating Temperature	T <sub>OP</sub>	0		70	°C	
Relative Humidity	RH	0		85	%	1
Damage Threshold, per Lane	DT	3.4			dBm	

### Notes:

Non-condensing.

**IV. Electrical Characteristics ( $T_{OP} = 0$  to  $70^{\circ}\text{C}$ ,  $V_{CC} = 3.1$  to  $3.45$  Volts)**

Parameter	Symbol	Min	Typ	Max	Unit	Ref.
Supply Voltage	Vcc1, VccTx, VccRx	3.15		3.45	V	
Supply Current	Icc			350	mA	1
<b>Link turn-on time</b>						
Transmit turn-on time				2000	ms	2
<b>Transmitter (per Lane)</b>						
Single ended input voltage tolerance	VinT	-0.3		4.0	V	
Differential data input swing	Vin,pp	180		1200	mVpp	3
Differential input threshold			50		mV	
AC common mode input voltage tolerance (RMS)		15			mV	
Differential input return loss		Per IEEE P802.3ba, Section 86A.4.1.1			dB	4
J2 Jitter Tolerance	Jt2	0.17			UI	
J9 Jitter Tolerance	Jt9	0.29			UI	
Data Dependent Pulse Width Shrinkage	DDPWS	0.07			UI	
Eye mask coordinates {X1, X2 Y1, Y2}		0.11, 0.31 95, 350			UI mV	5
<b>Receiver (per Lane)</b>						
Single-ended output voltage		-0.3		4.0	V	
Differential data output swing	Vout,pp	180		800	mVpp	7, 8
Differential input threshold			50	7.5	mV	
AC common mode output voltage (RMS)		15		5	mV	
Differential output return loss		Per IEEE P802.3ba, Section 86A.4.2.1			dB	4
Common mode output return loss		Per IEEE P802.3ba, Section 86A.4.2.2			dB	4
Output transition time, 20% to 80%		28			ps	
J2 Jitter output	Jo2			0.42	UI	
J9 Jitter output	Jo9			0.65	UI	
Eye mask coordinates #1 {X1, X2 Y1, Y2}		0.29, 0.5 150, 425			UI mV	6
Power Supply Ripple Tolerance	PSR	50			mVpp	

## Notes:

- Maximum total power value is specified across the full temperature and voltage range.
- From power-on and end of any fault conditions.
- After internal AC coupling. Self-biasing 100Ω differential input.
- 10 MHz to 11.1 GHz range
- Hit ratio =  $5 \times 10^{-5}$ .
- AC coupled with 100Ω differential output impedance.
- Settable in 4 discrete steps via the I2C interface.

**V. Optical Characteristics ( $T_{OP} = 0$  to  $70^{\circ}\text{C}$ ,  $V_{CC} = 3.1$  to  $3.45$  Volts)**

Parameter	Symbol	Min	Typ	Max	Unit	Ref.
Transmitter (per Lane)						
Signaling Speed per Lane			10.5		GBd	1
Center wavelength		840		860	nm	
RMS Spectral Width	SW			0.65	nm	
Average Launch Power per Lane	TXPx	-7.6		-1.0	dBm	
Transmit OMA per Lane	TxOMA	-5.6		3.0	dBm	2
Difference in Power between any two lanes [OMA]	DPx			4.0	dB	
Peak Power per Lane	PPx			4.0	dBm	
Launch Power [OMA] minus TDP perLane	P-TDP	-6.5			dBm	
TDP per Lane	TDP			3.5	dB	
Optical Extinction Ratio	ER	3.0			dB	
Optical Return Loss Tolerance	ORL			12	dB	
Encircled Flux	FLX	> 86% at 19 $\mu\text{m}$ < 30% at 4.5 $\mu\text{m}$			dB	
Average launch power of OFF transmitter, per lane				-30	dB	
Relative Intensity Noise	RIN			-128	dBm	
Transmitter eye mask definition {X1, X2, X3, Y1, Y2, Y3}		0.23, 0.34, 0.43, 0.27, 0.35, 0.4				

Parameter	Symbol	Min	Typ	Max	Unit	Ref.
Receiver per Lane						
Signaling Speed per Lane			10.5		GBd	3
Center wavelength		840		860	nm	
Damage Threshold	DT	3.4			dBm	
Average Receive Power per Lane	RXP <sub>x</sub>	-9.9		2.4	dBm	
Receive Power (OMA) per Lane	RxOMA			3.0	dBm	
Stressed Receiver Sensitivity (OMA) per Lane	SRS			-5.4	dBm	
Peak Power, per lane	PP <sub>x</sub>			4	dBm	
Receiver Reflectance	R <sub>fl</sub>			-12	dB	
Vertical eye closure penalty, per lane				1.9	dB	
Stressed eye J2 jitter, per Lane				0.3	UI	
Stressed eye J9 jitter, per Lane				0.47	UI	
OMA of each aggressor lane				-0.4	dBm	
Rx jitter tolerance: Jitter frequency and p-p amplitude		(75, 5)			kHz, UI	
		(375, 1)			kHz, UI	
LOS De-Assert	LOS <sub>D</sub>			-12	dBm	
LOS Assert	LOS <sub>A</sub>	-30			dBm	
LOS Hysteresis		0.5			dBm	

## Notes:

1. Transmitter consists of 4 lasers operating at a maximum rate of 10.5Gb/s each.
2. Even if TDP is <0.9dB, the OMA min must exceed this value.
3. Receiver consists of 4 photodetectors operating at a maximum rate of 10.5Gb/s each.

## VI. Memory Map and Control Registers

Compatible with the SFF-8436 QSFP+ MSA<sup>1</sup> and the SFF-8636 Common Management Interface MSA.<sup>2</sup> See Finisar Application Note AN-2119<sup>6</sup> for a complete EEPROM memory map.

## VII. Environmental Specifications

Finisar FTL410QE3C transceivers have an operating temperature range from 0°C to +70°C case temperature.

Environmental Specifications	Symbol	Min	Typ	Max	Units	Ref.
Case Operating Temperature	Top	0		70	°C	
Storage Temperature	Tsto	-40		85	°C	

**VIII. Regulatory Compliance**

Finisar FTL410QE3C transceivers are RoHS-6 Compliant. Copies of certificates are available at Finisar Corporation upon request.

FTL410QE3C transceiver modules are Class 1 laser eye safety compliant per IEC 60825-1, which means that they are eye safe under normal “unaided” viewing conditions. Laser radiation may be hazardous if viewed with magnifying optics.

**IX. Mechanical Specifications**

The FTL410QE3C mechanical specifications are compliant to the QSFP+ MSA transceiver module specifications.

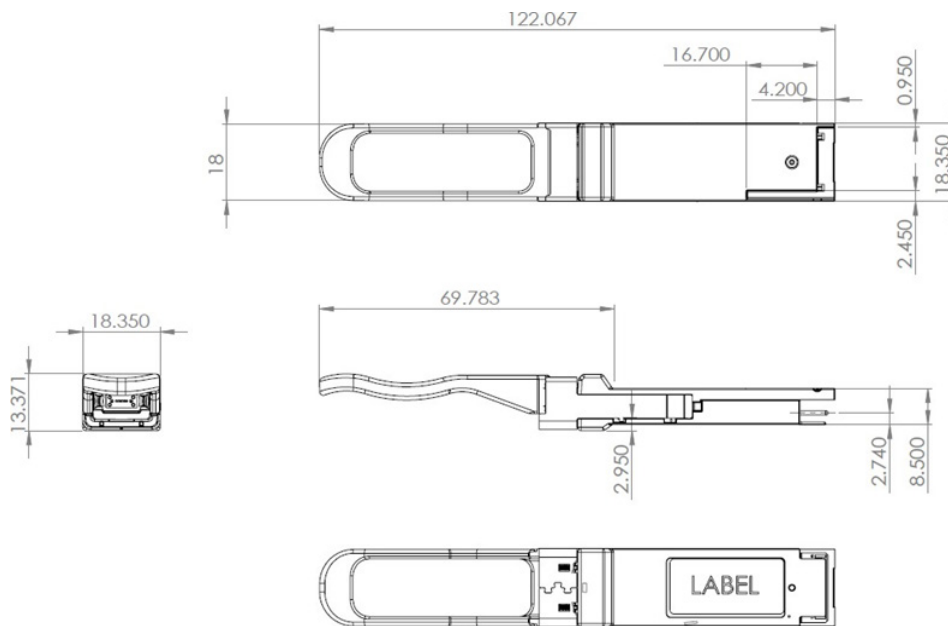

Figure 2 – FTL410QE3C mechanical drawing



Figure 3 – FTL410QE3C product label



The optical port is a male MPO connector receptacle, with fiber lane assignments as shown in Figure 4

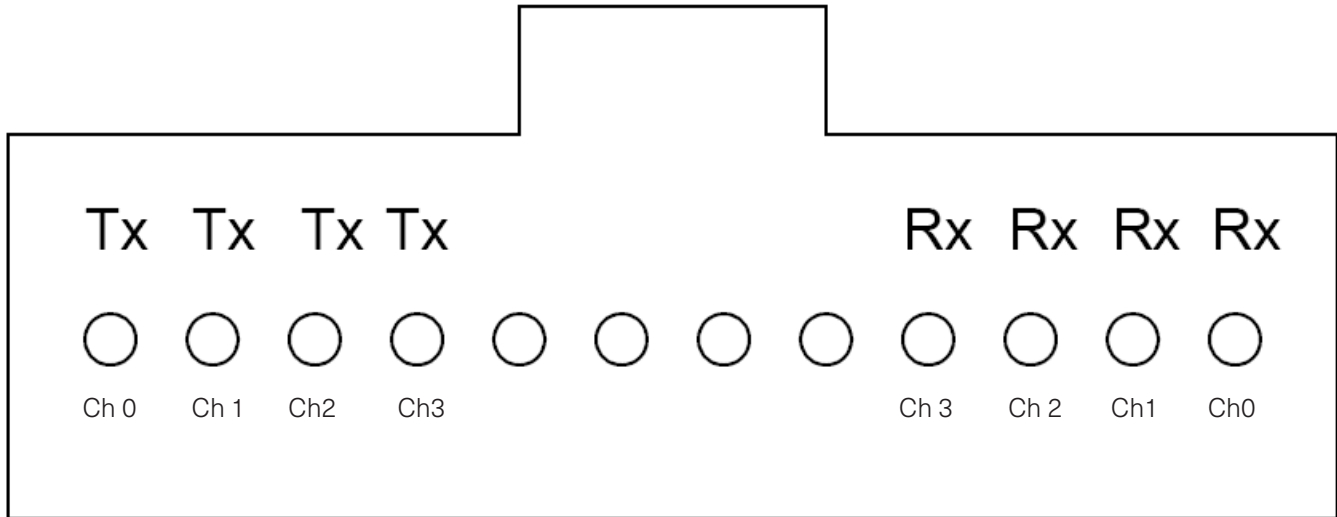

Figure 4 – FTL410QE3C optical lane assignment (front view of MPO receptacle)

## X. References

1. SFF-8436 – Specification for QSFP+ 10 Gbs 4x Pluggable Transceiver, Rev 4.8, October 2013.
2. SFF-8636 – Specification for Common Management Interface, Rev 2.4, November 2014.
3. IEEE 802.3ba – PMD Type 40GBASE-SR4.
4. Directive 2011/65/EU of the European Council Parliament and of the Council, “on the restriction of the use of certain hazardous substances in electrical and electronic equipment”. Certain products may use one or more exemptions as allowed by the Directive.
5. “Application Note AN-2038: Finisar Implementation of RoHS Compliant Transceivers”.
6. “Application Note AN-2119: QSFP+ 3rd Generation SR4 Transceiver – EEPROM Mapping”, Rev. B, Finisar Corporation, January, 2015.