

## Product Specification

### 200GBASE-SR4 QSFP56 Optical Transceiver Module

#### FTCC8612E2PCM

#### PRODUCT FEATURES

- Four-channel full-duplex transceiver module
- Hot-pluggable QSFP56 form factor
- Supports 212.5Gb/s aggregate bit rate
- Maximum link length of 100m on OM4 Multimode Fiber
- 200GAUI-4 C2M electrical interface (4x50Gb/s PAM4 retimed)
- 4x50Gb/s PAM4 VCSEL transmitter
- Power dissipation below 4.5W
- RoHS-6 compliant
- Operating case temperature range: 0°C to 70°C
- Single 3.3V power supply
- MPO-12 connector
- I2C management interface



#### APPLICATIONS

- 200G 100m on OM4 with FEC

Coherent FTCC8612E2PCM 200G QSFP56 SR4 transceiver modules are designed for use in 200 Gigabit Ethernet interfaces over multi-mode fiber. They are compliant with the QSFP MSA<sup>1</sup> and portions of IEEE 802.3-2018<sup>5</sup> and 802.3cd<sup>6</sup>. Digital diagnostics functions are available via the I2C interface, as specified by the CMIS 4.0<sup>4</sup>. The transceiver is RoHS compliant per Directive 2011/65/EU<sup>2</sup>. SFF-8636 could be supported by customized version.

#### PRODUCT SELECTION

### FTCC8612E2PCM

- 1: 100m max reach with OM4
- E: Ethernet protocol
- P: Pull-tab type release
- C: Commercial temperature range 0-70C
- M: MPO connector

### I. Pin Descriptions

QSFP56 pin-out as being defined by QSFP MSA<sup>1</sup>.

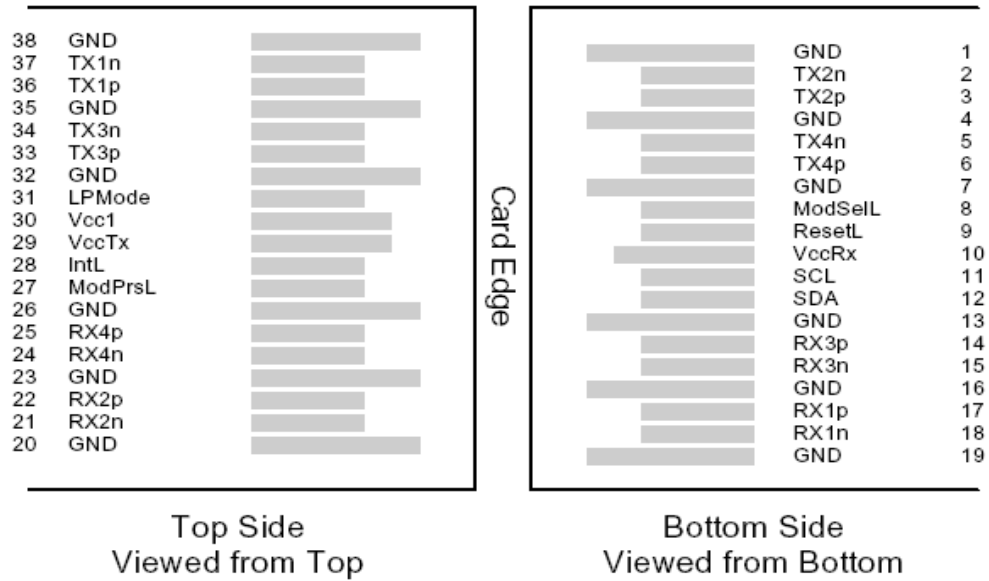

**Figure 1 – QSFP-compliant 38-pin connector (per SFF-8679)**

Pin	Symbol	Name/Description	Notes
1	GND	Ground	1
2	Tx2n	Transmitter Inverted Data Input	
3	Tx2p	Transmitter Non-Inverted Data Input	
4	GND	Ground	1
5	Tx4n	Transmitter Inverted Data Input	
6	Tx4p	Transmitter Non-Inverted Data Input	
7	GND	Ground	1
8	ModSelL	Module Select	
9	ResetL	Module Reset	
10	Vcc Rx	+3.3 V Power supply receiver	
11	SCL	2-wire serial interface clock	
12	SDA	2-wire serial interface data	
13	GND	Ground	1
14	Rx3p	Receiver Non-Inverted Data Output	
15	Rx3n	Receiver Inverted Data Output	
16	GND	Ground	1
17	Rx1p	Receiver Non-Inverted Data Output	
18	Rx1n	Receiver Inverted Data Output	
19	GND	Ground	1
20	GND	Ground	1
21	Rx2n	Receiver Inverted Data Output	
22	Rx2p	Receiver Non-Inverted Data Output	
23	GND	Ground	1
24	Rx4n	Receiver Inverted Data Output	

25	Rx4p	Receiver Non-Inverted Data Output	
26	GND	Ground	1
27	ModPrsL	Module Present	
28	IntL	Interrupt	
29	Vcc Tx	+3.3 V Power supply transmitter	
30	Vcc1	+3.3 V Power Supply	
31	LPMODE	Low Power Mode	
32	GND	Ground	1
33	Tx3p	Transmitter Non-Inverted Data Input	
34	Tx3n	Transmitter Inverted Data Input	
35	GND	Ground	1
36	Tx1p	Transmitter Non-Inverted Data Input	
37	Tx1n	Transmitter Inverted Data Input	
38	GND	Ground	1

## Notes

1. Circuit ground is internally isolated from chassis ground.

## II. Absolute Maximum Ratings

Module performance is not guaranteed beyond the operating range (see Section VI). Exceeding the limits below may damage the transceiver module permanently.

Parameter	Symbol	Min	Typ	Max	Unit	Ref.
Maximum Supply Voltage	V <sub>CC</sub>	-0.5		3.6	V	
Storage Temperature	T <sub>S</sub>	-40		85	°C	
Case Operating Temperature	T <sub>OP</sub>	0		70	°C	1
Relative Humidity	RH	15		85	%	2
Receiver Damage Threshold, per Lane	P <sub>Rdmg</sub>	5			dBm	

## Notes:

1. 48-hour excursions, maximum
2. Non-condensing.

## III. Electrical Characteristics (EOL, T<sub>OP</sub> = 0 to +70 °C, V<sub>CC</sub> = 3.135 to 3.465 Volts)

Parameter	Symbol	Min	Typ	Max	Unit	Ref.
Supply Voltage	V <sub>CC</sub>	3.135	3.3	3.465	V	
Supply Current	I <sub>CC</sub>			1.595	A	
Module total power	P			4.5	W	1
<b>Transmitter</b>						
Signaling rate per lane		26.5625± 100 ppm.			GBd	
Differential peak-peak input voltage tolerance	V <sub>in,pp,diff</sub>	900			mV	2
Differential input return loss		Per equation (83E-5) IEEE802.3-2018			dB	
Differential to common mode input return loss		Per equation (83E-6) IEEE802.3-2018			dB	
Differential termination mismatch				10	%	
Module stress input test		Per 120E.3.4.1 IEEE802.3-2018				3
Single-ended voltage tolerance range		-0.4		3.3	V	
DC common mode voltage		-350		2850	mV	4
<b>Receiver</b>						

Signaling rate per lane		26.5625± 100 ppm.		Gbd	
AC common-mode output voltage (RMS)				17.5	mV
Differential peak-to-peak output voltage				900	mV
Near-end ESMW (Eye symmetry mask width)		0.265			UI
Near-end Eye height, differential (min)		70			mV
Far-end ESMW (Eye symmetry mask width)		0.2			UI
Far-end Eye height, differential (min)		30			mV
Far-end pre-cursor ISI ratio		-4.5		2.5	%
Differential output return loss		Per equation 83E-2 IEEE802.3-2018			
Common to differential mode conversion return loss		Per equation 83E-3 IEEE802.3-2018			
Differential termination mismatch				10	%
Transition time (min, 20% to 80%)		9.5			ps
DC common mode voltage		-350		2850	mV
					4

**Notes:**

1. Maximum total power value is specified across the full temperature and voltage range.
2. With the exception to 120E.3.1.2 that the pattern is PRBS31Q or scrambled idle.
3. Meets specified BER
4. DC common mode voltage generated by the host. Specification includes effects of ground offset voltage.

**IV. Optical Characteristics (EOL, T<sub>OP</sub> = 0 to +70 °C, V<sub>CC</sub> = 3.135 to 3.465 Volts)**

Meets 200GBASE-SR4 as being defined by IEEE P802.3cd

Parameter	Symbol	Min	Typ	Max	Unit	Ref.
<b>Transmitter</b>						
Signaling rate (each lane (range))		26.5625± 100 ppm			GBd	
Modulation format		PAM4				
Lane wavelength (range)		840 to 860			nm	
RMS spectral width				0.6	nm	1
Average launch power, each lane				4	dBm	
Average launch power, each lane		-6.5			dBm	
Outer Optical Modulation Amplitude (OMA <sub>outer</sub> ), each lane		-4.5		3	dBm	2
Launch power in OMA <sub>outer</sub> minus TDECQ, each lane		-5.9			dBm	
Transmitter and dispersion eye closure for PAM4 (TDECQ), each lane				4.5	dB	
TDECQ – 10log <sub>10</sub> (C <sub>eq</sub> ), each lane				4.5	dB	3
Average launch power of OFF transmitter, each lane				-30	dBm	
Extinction ratio		3			dB	
Transmitter transition time, each lane				34	pS	
RIN <sub>12</sub> OMA				-128	dB/Hz	
Optical return loss tolerance				12	dB	
Encircled flux		≥ 86% at 19µm ≤ 30% at 4.5µm				4

**Notes:**

1. RMS spectral width is the standard deviation of the spectrum.
2. Even if the TDECQ < 1.4 dB, the OMA<sub>outer</sub> (min) must exceed this value.
3. C<sub>eq</sub> is a coefficient defined in 121.8.5.3, which accounts for the reference equalizer noise enhancement.
4. If measured into type A1a.2 or type A1a.3, or A1a.4, 50 µm fiber, in accordance with IEC 61280-1-4.

Parameter	Symbol	Min	Typ	Max	Unit	Ref.
<b>Receiver</b>						
Signaling rate (each lane (range))		26.5625± 100 ppm			GBd	
Modulation format		PAM4				
Lane wavelength (range)		840 to 860			nm	
Damage threshold, each lane		5			dBm	1
Average receive power, each lane				4	dBm	
Average receive power, each lane		-8.4			dBm	2
Receive power (OMA <sub>outer</sub> ), each lane				3	dBm	
Receiver reflectance				-12	dB	
Receiver sensitivity (OMA <sub>outer</sub> ), each lane				Equation (138-1)	dBm	3
Stressed receiver sensitivity (OMA <sub>outer</sub> ), each lane				-3.4	dBm	4
Conditions of stressed receiver sensitivity test:						5
Stressed eye closure for PAM4 (SECQ), lane under test		4.5			dB	
SECQ – 10log <sub>10</sub> (C <sub>eq</sub> ) <sub>f</sub> , each lane (max)		4.5			dB	6
OMA <sub>outer</sub> of each aggressor lane		3			dBm	
LOS De-Assert				-9	dBm	
LOS Assert		-30		-10	dBm	
LOS Hysteresis		0.5			dB	

**Notes:**

- The receiver shall be able to tolerate, without damage, continuous exposure to an optical input signal having this average power level on one lane. The receiver does not have to operate correctly at this input power.
- Average receive power, each lane (min) is informative and not the principal indicator of signal strength. A received power below this value cannot be compliant; however, a value above this does not ensure compliance.
- Receiver sensitivity is informative and is defined for a transmitter with a value of SECQ up to 4.5 dB (see figure 2 from IEEE 802.3cd clause 138)
- Measured with conformance test signal at TP3 (see IEEE 802.3cd 138.8.10) for the BER of 2.4E-4.
- These test conditions are for measuring stressed receiver sensitivity. They are not characteristics of the receiver.
- C<sub>eq</sub> is a coefficient defined in 121.8.5.3, which accounts for the reference equalizer noise enhancement.

**138.8.9 Receiver sensitivity**

Receiver sensitivity is informative and is defined for a transmitter with a value of SECQ up to 4.5 dB. Receiver sensitivity should meet Equation (138-1), which is illustrated in Figure 138-4.

$$RS = \max(-6.5, SECQ - 7.9) \quad (\text{dBm}) \tag{138-1}$$

where

*RS* is the receiver sensitivity  
*SECQ* is the SECQ of the transmitter used to measure the receiver sensitivity

The normative requirement for receivers is stressed receiver sensitivity.

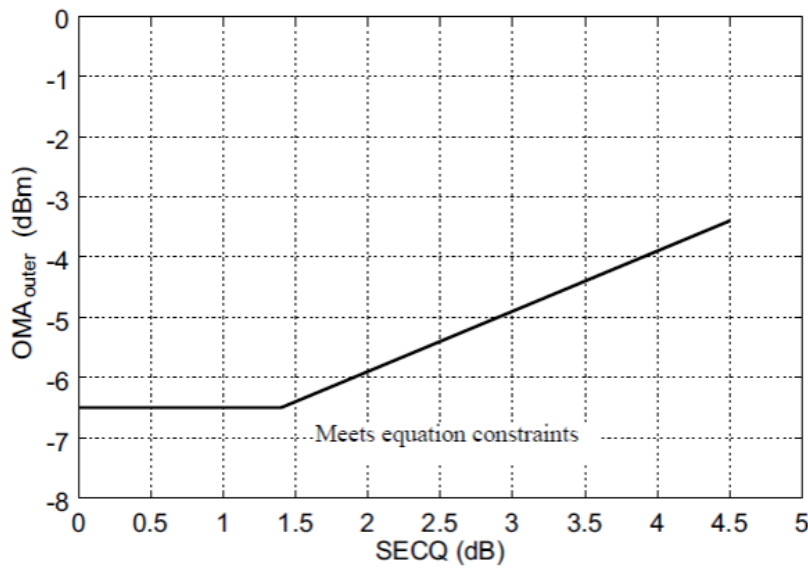

Figure 138-4—Illustration of receiver sensitivity

Figure 2 – Receiver sensitivity (per IEEE 802.3cd)

**V. General Specifications**

Parameter	Symbol	Min	Typ	Max	Units	Ref.
Bit Rate (all wavelengths combined)	BR			212.5	Gb/s	1
Bit Error Ratio	BER			2.4E-4		2
<b>Maximum Supported Distances</b>						
Fiber Type						
OM3 MMF	Lmax1			70	m	
OM4 MMF	Lmax2			100		

Notes:

1. Supports 200GBASE-SR4 per IEEE P802.3cd.
2. The typical BER is better than 1E-6 when Measured with a transmitter to produce SECQ up to 3dB.

## VI. Environmental Specifications

Coherent FTCC8612E2PCM QSFP56 SR4 transceivers have an operating case temperature range of 0°C to +70°C.

Parameter	Symbol	Min	Typ	Max	Units	Ref.
Case Operating Temperature	T <sub>op</sub>	0		+70	°C	1
Storage Temperature	T <sub>sto</sub>	-40		85	°C	
Relative Humidity	RH	15		85	%	2

### Notes:

1. 48-hour excursions, maximum
2. Non-condensing.

## VII. Regulatory Compliance

Coherent FTCC8612E2PCM QSFP56 SR4 transceivers are Class 1 Laser Products. They are certified per the following standards:

Feature	Agency	Standard
Laser Eye Safety	FDA/CDRH	CDRH 21 CFR 1040.10 and Laser Notice 56
Laser Eye Safety	UL/CSA/TÜV	IEC/EN 60825-1:2014 IEC/EN 60825-2: 2004+A1+A2
Electrical Safety	UL/CSA/TÜV	IEC/UL/EN 62368-1:2014

Caution: Use of controls or adjustments or performance of procedures other than those specified herein may result in hazardous radiation exposure.

Copies of the referenced certificates are available at Coherent upon request.

**VIII. Digital Diagnostics Functions**

FTCC8612E2PCM QSFP56 SR4 transceivers support the I2C-based diagnostics interface specified by the QSFP MSA<sup>1</sup>.

**IX. Memory Contents**

Per CMIS 4.0<sup>4</sup>. SFF-8636 could be supported by customized version.

**XI. Mechanical Specifications**

Coherent FTCC8612E2PCM QSFP56 SR4 transceivers are compatible with the QSFP MSA specification for QSFP pluggable form factor modules.

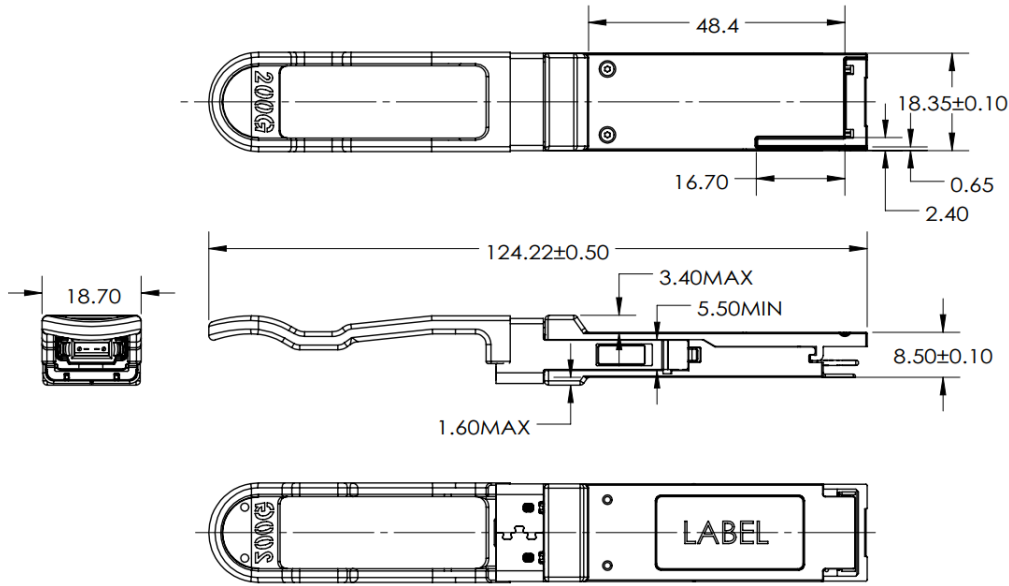

**Figure 3. FTCC8612E2PCM Mechanical Dimensions**

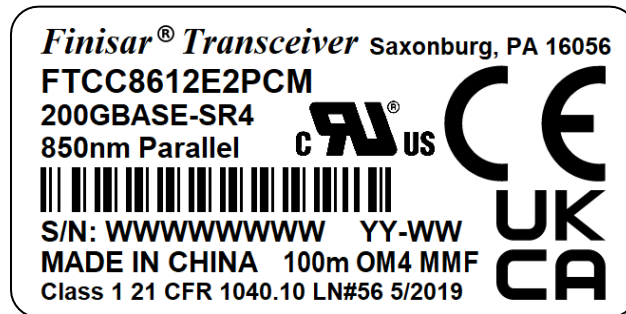

**Figure 4. Standard Product Label (not to scale)**



## **XII. References**

1. SFF-8665: “QSFP+ 28Gb/s 4X Pluggable Transceiver Solution (QSFP28)”, Rev 1.9, June 29, 2015 and associated SFF documents referenced therein:
  - i. SFF-8661
  - ii. SFF-8679
  - iii. SFF-8662
  - iv. SFF-8663
  - v. SFF-8672
  - vi. SFF-8472
2. Directive 2011/65/EU of the European Parliament and of the Council, “on the restriction of the use of certain hazardous substances in electrical and electronic equipment,” July 1, 2011.
3. “Application Note AN-2038: Coherent Implementation Of RoHS Compliant Transceivers”, January 21, 2005.
4. Common Management Interface Specification (CMIS) Rev 4.0.
5. IEEE P802.3-2018, 200GAUI-4 Interface.
6. IEEE P802.3cd

### **For More Information:**

Coherent Corp.  
375 Saxonburg Boulevard  
Saxonburg, PA 16056  
[sales@coherent.com](mailto:sales@coherent.com)  
[www.coherent.com](http://www.coherent.com)