

FTLC1122RDNL

10km 100GBASE-LR4 CFP2 Optical Transceiver Module

2nd generation, FTLC1122RDNL 100G CFP2 transceiver modules are designed for use in 100 Gigabit Ethernet interfaces over single mode fiber. They are compliant with the CFP MSA¹ and IEEE 802.3ba 100GBASE-LR4² specifications. Digital diagnostics functions are available via the MDIO interface, as specified by the CFP MSA and Finisar Application Note AN-21185. The transceiver is RoHS compliant and lead-free per Directive 2011/65/EU³, and Finisar Application Note AN-2038⁴.



FEATURES

- Hot-pluggable CFP2 form factor
- Supports 103.1Gb/s aggregate bit rates
- Power dissipation < 5W
- RoHS-6 compliant (lead-free)
- Commercial case temperature range of 0°C to 75°C
- Single 3.3V power supply
- Maximum link length of 10km on
- Single Mode Fiber (SMF)
- 4x26Gb/s DFB-based
- LAN-WDM transmitter
- 4x26G electrical interface
- Duplex LC receptacles
- MDIO management interface

APPLICATIONS

- 100GBASE-LR4 100G Ethernet

Product Selection

FTLC1122RDNL

- R: 100GE-LR4 maximum bit rate (103.1 Gb/s)
- D: 4x25G LAN-WDM optical architecture
- N: Flat top module (no heat sink)
- L: LC straight receptacles

I. Pin Descriptions

Per CFP MSA¹.

	TopRow		BottomRow			TopRow		BottomRow
104	GND	1	GND		78	{REFCLKp}	27	MOD_ABS
103	N.C.	2	{TX_MCLKn}		77	GND	28	MOD_RSTn
102	N.C.	3	{TX_MCLKp}		76	N.C.	29	GLB_ALRMn
101	GND	4	GND		75	N.C.	30	GND
100	TX3n	5	N.C.		74	GND	31	MDC
99	TX3p	6	N.C.		73	RX3n	32	MDIO
98	GND	7	3.3V_GND		72	RX3p	33	PRTADR0
97	TX2n	8	3.3V_GND		71	GND	34	PRTADR1
96	TX2p	9	3.3V		70	RX2n	35	PRTADR2
95	GND	10	3.3V		69	RX2p	36	VND_IO_C
94	N.C.	11	3.3V		68	GND	37	VND_IO_D
93	N.C.	12	3.3V		67	N.C.	38	VND_IO_E
92	GND	13	3.3V_GND		66	N.C.	39	3.3V_GND
91	N.C.	14	3.3V_GND		65	GND	40	3.3V_GND
90	N.C.	15	VND_IO_A		64	N.C.	41	3.3V
89	GND	16	VND_IO_B		63	N.C.	42	3.3V
88	TX1n	17	PRG_CNTL1		62	GND	43	3.3V
87	TX1p	18	PRG_CNTL2		61	RX1n	44	3.3V
86	GND	19	PRG_CNTL3		60	RX1p	45	3.3V_GND
85	TX0n	20	PRG_ALRM1		59	GND	46	GND
84	TX0p	21	PRG_ALRM2		58	RX0n	47	N.C.
83	GND	22	PRG_ALRM3		57	RX0p	48	N.C.
82	N.C.	23	GND		56	GND	49	GND
81	N.C.	24	TX_DIS		55	N.C.	50	{RX_MCLKn}
80	GND	25	RX_LOS		54	N.C.	51	{RX_MCLKp}
79	{REFCLKn}	26	MOD_LOPWR		53	GND	52	GND

Bottom Row Pin Descriptions

PIN#	Name	I/O	Logic	Description
1	GND			
2	TX_MCLKn			Supported.
3	TX_MCLKp			Supported.
4	GND			
5	N.C.			
6	N.C.			
7	3.3V_GND			3.3V Module Supply Voltage Return Ground, internally connected to Signal Ground
8	3.3V_GND			3.3V Module Supply Voltage Return Ground, internally connected to Signal Ground
9	3.3V			3.3V Module Supply Voltage
10	3.3V			3.3V Module Supply Voltage
11	3.3V			3.3V Module Supply Voltage
12	3.3V			3.3V Module Supply Voltage
13	3.3V_GND			3.3V Module Supply Voltage Return Ground, internally connected to Signal Ground
14	3.3V_GND			3.3V Module Supply Voltage Return Ground, internally connected to Signal Ground
15	VND_IO_A	I/O		Module Vendor I/O A. Do Not Connect!
16	VND_IO_B	I/O		Module Vendor I/O B. Do Not Connect!
17	PRG_CNTL1	I	LVC MOS w/ PUR	Programmable Control 1 set over MDIO
18	PRG_CNTL2	I	LVC MOS w/ PUR	Programmable Control 2 set over MDIO
19	PRG_CNTL3	I	LVC MOS w/ PUR	Programmable Control 3 set over MDIO
20	PRG_ALRM1	O	LVC MOS	Programmable Alarm 1 set over MDIO
21	PRG_ALRM2	O	LVC MOS	Programmable Alarm 2 set over MDIO
22	PRG_ALRM3	O	LVC MOS	Programmable Alarm 3 set over MDIO
23	GND			
24	TX_DIS	I	LVC MOS w/ PUR	Transmitter Disable for all lanes, "1" or NC = transmitter disabled, "0" = transmitter enabled
25	RX_LOS	O	LVC MOS	Receiver Loss of Optical Signal, "1": low optical signal, "0": normal condition
26	MOD_LOP- WR	I	LVC MOS w/ PUR	Module Low Power Mode. "1" or NC: module in low power (safe) mode, "0": power-on enabled
27	MOD_ABS	O	GND	Module Absent. "1" or NC: module absent, "0": module present, Pull Up Resistor on Host
28	MOD_RSTn	I	LVC MOS w/ PDR	Module Reset. "0" resets the module, "1" or NC = module enabled, Pull Down Resistor in Module
29	GLB_AL- RMn	O	LVC MOS	Global Alarm. "0": alarm condition in any MDIO Alarm register, "1": no alarm condition, Open Drain, Pull Up Resistor on Host
30	GND			
31	MDC	I/O	1.2V CMOS	Management Data I/O bi-directional data (electrical specs as per 802.3ae and ba)
32	MDIO	I	1.2V CMOS	Management Data Clock (electrical specs as per 802.3ae and ba)
33	PRTADR0	I	1.2V CMOS	MDIO Physical Port address bit 0

PIN#	Name	I/O	Logic	Description
34	PRTADR1	I	1.2V CMOS	MDIO Physical Port address bit 1
35	PRTADR2	I	1.2V CMOS	MDIO Physical Port address bit 2
36	VND_IO_C	I/O		Module Vendor I/O C. Do Not Connect!
37	VND_IO_D	I/O		Module Vendor I/O D. Do Not Connect!
38	VND_IO_E	I/O		Module Vendor I/O E. Do Not Connect!
39	3.3V_GND			3.3V Module Supply Voltage Return Ground, internally connected to Signal Ground
40	3.3V_GND			3.3V Module Supply Voltage Return Ground, internally connected to Signal Ground
41	3.3V			3.3V Module Supply Voltage
42	3.3V			3.3V Module Supply Voltage
43	3.3V			3.3V Module Supply Voltage
44	3.3V			3.3V Module Supply Voltage
45	3.3V_GND			3.3V Module Supply Voltage Return Ground, internally connected to Signal Ground
46	GND			
47	N.C.			
48	N.C.			
49	GND			
50	RX_MCLKn			Supported.
51	RX_MCLKp			Supported.
52	GND			

II. Absolute Maximum Ratings

Module performance is not guaranteed beyond the operating range (see Section VI). Exceeding the limits below may damage the transceiver module permanently.

Parameter	Symbol	Min	Typ	Max	Unit	Ref.
Maximum Supply Voltage	V _{cc}	-0.5		4.0	V	
Storage Temperature	TS	-40		85	°C	
Case Operating Temperature	TOP	0		70	°C	
Relative Humidity	RH	15		85	%	1
Receiver Damage Threshold, per Lane	PRdmg	5.5			dBm	

Notes:
Non-condensing.

III. Electrical Characteristics (EOL, T_{OP}=0 to 70°C, V_{CC}=3.2 to 3.4 Volts)

Parameter	Symbol	Min	Typ	Max	Unit	Ref.
Supply Voltage	V _{cc}	3.2		3.4	V	
Supply Current	I _{cc}			2.5	A	
Module total power	P		4.5	5	W	1
Transmitter						
Signaling rate per lane				25.78	Gb/s	2
Input differential impedance	R _{in}	CAUI-4 as defined by IEEE P802.3bm			Ω	3
Differential data input swing per lane	V _{in,pp}				mV	4
Data input rise time tolerance	t _r				ps	5
Data input rise time tolerance	t _f				ps	5
Electrical input eye mask definition	{X1,X2} {Y1,Y2}				UI mV	
Receiver						
Signaling rate per lane				25.78	Gb/s	2
Differential data output swing per lane	V _{out,pp}	CAUI-4 as defined by IEEE P802.3bm			mV	
Data output rise time	t _r				ps	5
Data output fall time	t _f				ps	5
Electrical output eye mask definition	{X1,X2} {Y1,Y2}				UI mV	
Power Supply Noise Tolerance	V _{rip}	Per Table 4-1 in the CFP2 MSA document ¹				6

Notes:
1. Maximum total power value is specified across the full temperature and voltage range.
2. +/- 100ppm

FTLC1122RDNL Clocking Signals

Clock Name	Status	I/O	Value
REFCLK	Not Required	I	N/A (terminated internally)
TX_MCLK	Supported	O	1/8 of network line rate
RX_MCLK	Supported	O	1/8 of network line rate

IV. Optical Characteristics (EOL, TOP = 0 to 75°C, VCC = 3.2 to 3.4 Volts)

Parameter	Symbol	Min	Typ	Max	Unit	Ref.
Transmitter						
Signaling Speed per Lane		25.78		25.78	Gb/s	1
Lane center wavelengths (range)		1294.53 – 1296.59 1299.02 – 1301.09 1303.54 – 1305.63 1308.09 – 1310.19			nm	
Total Average Launch Power	P_{OUT}			10.5	dBm	
Transmit OMA per Lane	TxOMA	-1.3		4.5	dBm	
Average Launch Power per Lane	TXPx	-4.3		4.5	dBm	2
Optical Extinction Ratio	ER	4			dB	
Sidemode Suppression ratio	SSR _{min}	30			dB	
Transmitter Dispersion Penalty	TDP		0.3	2.2	dB	
Average launch power of OFF transmitter, per lane				-30	dBm	
Relative Intensity Noise				-130	dB/Hz	
Optical Return Loss Tolerance				20	dB	
Transmitter Reflectance				-12	dB	
Transmitter eye mask definition {X1, X2, X3, Y1, Y2, Y3}		{0.25, 0.4, 0.45, 0.25, 0.28, 0.4}				
Receiver						
Signaling Speed per Lane		25.78		25.78	GBd	3
Lane center wavelengths (range)		1294.53 – 1296.59 1299.02 – 1301.09 1303.54 – 1305.63 1308.09 – 1310.19			nm	
Receive Power (OMA) per Lane	RxOMA			4.5	dBm	
Average Receive Power per Lane	RXPx	-10.6		4.5	dBm	4
Receiver Sensitivity (OMA) per Lane	Rxsens			-8.6	dBm	
Stressed Receiver Sensitivity (OMA) per Lane	SRS			-6.8	dBm	
Return Loss	RL	-26			dB	
Vertical eye closure penalty, per lane				1.8	dB	
Receive electrical 3 dB upper cutoff frequency, per lane				31	GHz	
LOS De-Assert	LOS _D			-11.6	dBm	
LOS Assert	LOS _A			-13.6	dBm	
LOS Hysteresis			1			

Notes:

1. Transmitter consists of 4 lasers operating at 25.78Gb/s each.
2. Minimum value is informative.
3. Receiver consists of 4 photodetectors operating at 25.78Gb/s each.
4. Minimum value is informative, equals min TxOMA with infinite ER and max channel insertion loss.

V. General Specifications

Parameter	Symbol	Min	Typ	Max	Units	Ref.
Bit Rate (all wavelengths combined)	BR			103.1	Gb/s	1
Bit Error Ratio @25.78Gb/s	BER1			10 ⁻¹²		2
Maximum Supported Distances						
Fiber Type						
SMF per G.652	Lmax1			10	km	

Notes:

1. Supports 100GBASE-LR4 per IEEE 802.3ba.
2. Tested with a 231 – 1 PRBS.

VI. Environmental Specifications

Finisar FTLC1122 CFP2 transceivers have a commercial operating case temperature range of 0°C to +75°C.

Parameter	Symbol	Min	Typ	Max	Units	Ref.
Case Operating Temperature	T _{op}	0		75	°C	
Storage Temperature	T _{sto}	-40		85	°C	

VII. Regulatory Compliance

Finisar FTLC1122 CFP2 transceivers are Class 1 Laser Products. They are certified per the following standards:

Feature	Agency	Standard	Certificate Number
Laser Eye Safety	FDA/CDRH	CDRH 21 CFR 1040 and Laser Notice 50	9210176
	CSA	IEC60825-1:2014	70119867
	TüV	EN60825-1: 2014 EN 60825-2: 2004+A1+A2	R72130387
Electrical Safety	CSA	IEC60950-1:2005+A1+A2,	70119867
	TüV	EN60950-1:2006+A11+A1+A12+A2	R72130387
	CSA	CAN/CSA-C22.2 no 60950-1-07+A1, UL 60950-1-2011	2375840

Copies of the referenced certificates are available at Finisar Corporation upon request.

VIII. Digital Diagnostics Functions

FTLC1122 CFP2 transceivers support the MDIO-based diagnostics interface specified in the CFP MSA¹. See Finisar Application Note AN-2118.

IX. Memory Contents

Per the CFP MSA¹. See Finisar Application Note AN-2118.

X. Host PCB Layout and Bezel Recommendations

Per CFP2 Hardware Specification¹.

XI. Mechanical Specifications

Finisar FTLC1122 CFP2 transceivers are compatible with the CFP2 Hardware Specification for pluggable form factor modules.

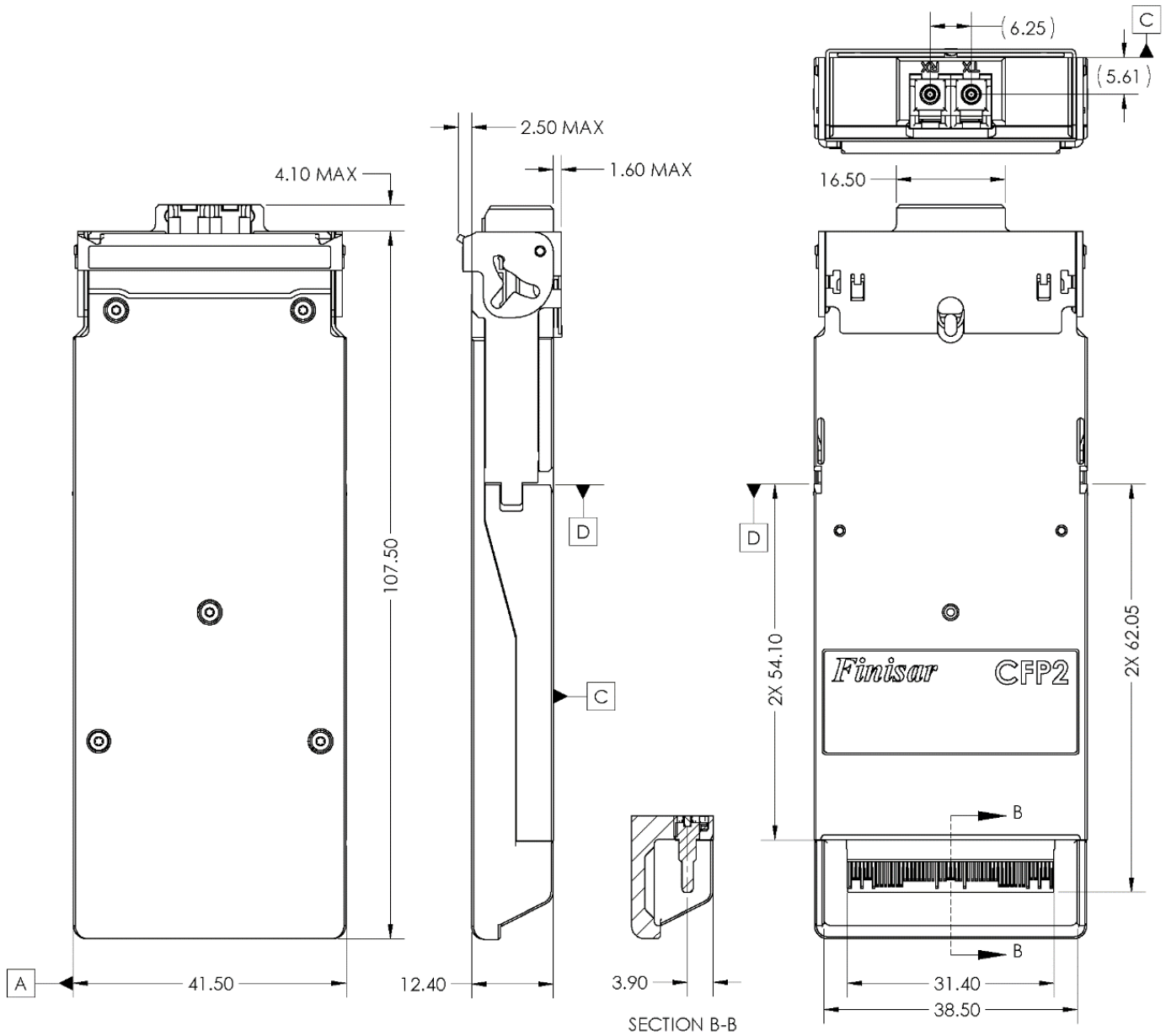

Figure 1. FTLC1122RDNL Mechanical Dimensions.



Figure 4. Standard Product Label

XII. References

1. CFP2 Hardware Specification and CFP MSA Management Interface Specifications (MIS), Rev 2.4.; CFP MSA, www.cfp-msa.org
2. IEEE 802.3ba, PMD Type 100GBASE-LR4.
3. Directive 2011/65/EU of the European Council Parliament and of the Council, "on the restriction of the use of certain hazardous substances in electrical and electronic equipment," June 8, 2011.
4. "Application Note AN-2038: Finisar Implementation Of RoHS Compliant Transceivers", Finisar Corporation, January 21, 2005.
5. Application Note AN-2118, Finisar Corporation.
6. IEEE P802.3bm, CAUI-4 Interface.